

ROTTLER

SG INSERT PROFILE CATALOG



ORDERING PROCEDURE

Contact your regional Rottler sales rep for assistance in ordering optional equipment, replacement parts, or tooling.

If you are unable to contact your regional Rottler sales rep, call the factory at 253-872-7050 and ask to speak to the parts sales specialist.

Have the following information handy to expedite the ordering process:

1. Your name, business name, and contact number
2. Customer number
3. If you don't have a customer number, your billing address
4. Shipping address if different from billing address
5. Machine model and serial number
6. Part number and description of what you want to order
7. Preferred method of shipment

You may also contact us via e-mail with the above information. Send e-mail requests to:
parts@rottermfg.com

In some cases you may be requested to send a photo of the part you are ordering if it is a replacement part, or doesn't appear in the database.

If you are unsure which part you need to order, contact our service department and ask to speak to one of our service consultants. They will assist you in determining which part you require.

THERE IS A MINIMUM ORDER OF \$25.00



Contents

Rottler Special Profile Cutter Inserts Policy 1

Suggested Carbide Cutting Inserts 1

Automotive Import, Domestic and Diesel Inserts..... 1

Suggested 45 Degree Seat Inserts..... 1

RCA001 Carbide Seat Insert 30-45-60 / 1.2 -1.01

RCA004 Carbide Seat Insert 30-45-60 / 1.6 -1.31

RCA005 Carbide Seat Insert 37-45-52 / 2.0 -1.31

RCA007 Carbide Seat Insert 37-45-52 / 1.8 -1.51

RCA014 Carbide Seat Insert 30-45-60 / 1.4 -1.61

RCA026 Carbide Seat Insert 30-45-60 / 1.6 -1.91

Suggested 30 Degree Seat Inserts..... 2

RCA301 Carbide Seat Insert 15-30-45 / 2.0 -1.32

RCA303 Carbide Seat Insert 15-30-45 / 1.4 -1.52

RCA307 Carbide Seat Insert 15-30-45 / 1.8 -1.62

RCA348 Carbide Seat Insert 10-30-60 / 2.64 - 2.16 OFFSET Insert (For Detroit 53 Series Cylinder Head).....2

Suggested 37.5 Degree Seat Inserts..... 2

RCA401 Carbide Seat Insert 30- 37.5 -60 / 2.0 -1.62

Suggested Straight Angle seat Inserts..... 3

RCA511 Carbide Seat Insert 94 degrees R 0.8 / 12mm (SHORT PROFILE for counterboring).....3

RCA512 Carbide Seat Insert 94 degrees R 0.8 / 15.3mm (for counterboring).....3

RCA513 Carbide Seat Insert 94-R0.5 / 2.5-6.5 (OFFSET FOR COUNTERBORING SMALL SEATS)3

RCA501 Carbide Seat Insert 20 degrees / 8.8mm.....3

RCA521 Carbide Seat Insert 25 degrees / 8.5mm.....3

RCA502 Carbide Seat Insert 30 degrees / 9.0mm.....3

RCA503 Carbide Seat Insert 45 degrees / 8.9 mm.....3

RCB506 Carbide Seat Insert 70 degrees / 16.8mm.....3

Suggested 45 Degree Seat Inserts for Multi-Valves Cylinder Heads 4

RCA632 Carbide Seat Insert 30-94-R1.5-30-45-60 / 1.6-1.34

RCA637 Carbide Seat Insert R1.5-32-45-60 / 1.6-1.0-1.04

High Performance Inserts..... 5

RCB605 Carbide Seat Insert 35-45-55-65-75 / 2.5-1.0-2.5-2.5.....5

RCB607 Carbide Seat Insert R1.5-35-45-R12-75-R3.5 / 1.9-1.5-1.5-3.0.....5

RCB608 Carbide Seat Insert R1.5-35-45-R12-75-R3.5-45 / 1.9-1.5-1.0-3.05

RCA614 Carbide Seat Insert R4 -15 / 5.52mm.....6

RCB620 Carbide Seat Insert R7 -15.....6

RCB621 Carbide Seat Insert 75 - R7 / 12.0mm.....6

RCA623 Carbide Seat Insert R0.8-30-45-60-R13-R1.5 / 1.0-1.0.....6



Harley Davidson Inserts..... 7

RCA626 Carbide Seat Insert R1.5-30-45-60 / 1.6-1.0..... 7

RCA633 Carbide Seat Insert 30-45-60 / 2.0 -1.4 7

RCA640 Carbide Seat Insert R1.5-32-45-60 / 1.6-1.2..... 7

Rottler Cutter Inserts Profiles 7

RCA001 Carbide Seat Insert 30-45-60 / 1.2 -1.0 7

RCA001-P Carbide Seat Insert 30-45-60 / 1.2 -1.0 Short Bottom Angle (Perkins Requirements)..... 7

RCA002 Carbide Seat Insert 30-45-60 / 2.0 -1.0 7

RCA003 Carbide Seat Insert 30-45-60 / 1.2 -1.3 8

RCA004 Carbide Seat Insert 30-45-60 / 1.6 -1.3 8

RCA005 Carbide Seat Insert 37-45-52 / 2.0 -1.3 8

RCA006 Carbide Seat Insert 30-45-52 / 2.0 -1.3 8

RCA007 Carbide Seat Insert 37-45-52 / 1.8 -1.5 8

RCA008 Carbide Seat Insert 15-45-60 / 1.8 -1.5 8

RCA009 Carbide Seat Insert 30-45-52 / 1.8 -1.5 8

RCA010 Carbide Seat Insert 30-45-60 / 2.0 -1.5 8

RCA011 Carbide Seat Insert 30-45-60 / 3.0 -1.5..... 8

RCA012 Carbide Seat Insert 30-45-52 / 1.2 -1.6 9

RCA013 Carbide Seat Insert 30-45-60 / 1.2 -1.6 9

RCA014 Carbide Seat Insert 30-45-60 / 1.4 -1.6 9

RCA015 Carbide Seat Insert 15-45-60 / 1.6 -1.6 9

RCA016 Carbide Seat Insert 30-45-52 / 1.6 -1.6 9

RCA017 Carbide Seat Insert 30-45-60 / 2.0 -2.2 9

RCA018 Carbide Seat Insert 30-45-52 / 1.8 -1.6 9

RCA019 Carbide Seat Insert 15-45-60 / 2.0 -1.6 9

RCA020 Carbide Seat Insert 30-45-52 / 2.0 -1.6 9

RCA021 Carbide Seat Insert 30-45-60 / 2.0 -1.6 10

RCA022 Carbide Seat Insert 30-45-60 / 3.0 -1.6 10

RCA023 Carbide Seat Insert 30-45-60 / 3.0 -1.8 10

RCA024 Carbide Seat Insert 30-45-52 / 1.2 -1.9 10

RCA025 Carbide Seat Insert 30-45-60 / 1.2 -1.9 (Caterpillar 3500E Intake seat Profile)..... 10

RCA026 Carbide Seat Insert 30-45-60 / 1.6 -1.9 10

RCA027 Carbide Seat Insert 30-45-52 / 1.8 -1.9 10

RCA028 Carbide Seat Insert 30-45-52 / 2.0 -1.9 10

RCA029 Carbide Seat Insert 30-45-60 / 2.0 -1.9 10

RCA030 Carbide Seat Insert 30-45-70 / 1.6 -2.0 11

RCA031 Carbide Seat Insert 30-45-75 / 1.6 -2.0 11

RCA032 Carbide Seat Insert 30-45-60 / 0.6 -2.2 11

RCA033 Carbide Seat Insert 30-45-60 / 2.0 -2.3 11

RCA034 Carbide Seat Insert 30-45-60 / 2.0 -2.5 11



RCA035	Carbide Seat Insert	25-45-60 / 1.4 -1.0	11
RCA036	Carbide Seat Insert	25-45-60 / 1.8 -1.0	11
RCA037	Carbide Seat Insert	35-45-52 / 1.6 -1.0	11
RCA038	Carbide Seat Insert	35-45-55 / 1.6 -1.0	11
RCA039	Carbide Seat Insert	35-45-60 / 1.6 -1.0	12
RCA040	Carbide Seat Insert	30-45-60 / 2.0 -1.3	12
RCA041	Carbide Seat Insert	30-45-60 / 1.0 -1.3	12
RCA042	Carbide Seat Insert	30-45-60 / 1.0 -1.4	12
RCA043	Carbide Seat Insert	30-45-60 / 1.8 -1.5	12
RCA044	Carbide Seat Insert	30-45-60 / 1.4 -1.5	12
RCA045	Carbide Seat Insert	25-45-60 / 1.4 -1.6	12
RCA046	Carbide Seat Insert	25-45-60 / 1.8 -1.6	12
RCA047	Carbide Seat Insert	30-45-60 / 1.0 -1.6	12
RCA048	Carbide Seat Insert	30-45-60 / 2.0 -1.7	13
RCA049	Carbide Seat Insert	30-45-60 / 1.6 -1.8	13
RCA050	Carbide Seat Insert	30-45-52 / 0.8 -1.9	13
RCA051	Carbide Seat Insert	25-45-60 / 1.4 -2.0	13
RCA052	Carbide Seat Insert	25-45-60 / 1.8 -2.0	13
RCA053	Carbide Seat Insert	30-45-60 / 1.2 -2.0	13
RCA054	Carbide Seat Insert	25-45-60 / 1.4 -2.5	13
RCA055	Carbide Seat Insert	25-45-60 / 1.8 -2.5	13
RCA056	Carbide Seat Insert	30-45-60 / 1.8 -1.0	13
RCA057	Carbide Seat Insert	37-45-52 / 2.0 -1.0	14
RCA058	Carbide Seat Insert	25-45-52 / 1.9 -1.6	14
RCA059	Carbide Seat Insert	25-45-52 / 2.3 -1.7	14
RCA077	Carbide Seat Insert	25-45-60 / 1.4-1.2	14
RCA300	Carbide Seat Insert	15-30-45 / 1.0 -1.3	14
RCA301	Carbide Seat Insert	15-30-45 / 2.0 -1.3	14
RCA302	Carbide Seat Insert	15-30-60 / 2.0 -1.3	14
RCA303	Carbide Seat Insert	15-30-45 / 1.4 -1.5	14
RCA304	Carbide Seat Insert	15-30-45 / 1.8 -1.5	14
RCA305	Carbide Seat Insert	15-30-60 / 2.0 -1.5	15
RCA306	Carbide Seat Insert	15-30-45 / 1.2 -1.6	15
RCA307	Carbide Seat Insert	15-30-45 / 1.8 -1.6	15
RCA308	Carbide Seat Insert	15-30-52 / 1.8 -1.6	15
RCA309	Carbide Seat Insert	15-30-45 / 2.0 -1.6	15
RCA310	Carbide Seat Insert	15-30-60 / 2.0 -1.6	15
RCA311	Carbide Seat Insert	15-30-60 / 2.2 -1.6	15
RCA312	Carbide Seat Insert	15-30-45 / 2.0 -1.8	15
RCA313	Carbide Seat Insert	15-30-45 / 1.0 -1.9	15



RCA314	Carbide Seat Insert	15-30-60 / 2.0 -1.9	16
RCA315	Carbide Seat Insert	15-30-45 / 1.2 -2.0 (Caterpillar 3500E Exhaust seat Profile)	16
RCA316	Carbide Seat Insert	15-30-45 / 2.0 -2.0	16
RCA317	Carbide Seat Insert	15-30-60 / 2.0 -2.2	16
RCA318	Carbide Seat Insert	20-30-45 / 3.0 -3.8	16
RCA321	Carbide Seat Insert	20-30-52 / 1.6 -1.0	16
RCA322	Carbide Seat Insert	0-30-60 / 2.0 -1.5	16
RCA323	Carbide Seat Insert	15-30-60 / 1.8 -1.5	16
RCA324	Carbide Seat Insert	15-30-60 / 2.2 -1.5	16
RCA325	Carbide Seat Insert	20-30-60 / 3.0 -1.5	17
RCA326	Carbide Seat Insert	15-30-60 / 1.4 -2.0	17
RCA327	Carbide Seat Insert	15-30-60 / 1.8 -2.0	17
RCA328	Carbide Seat Insert	15-30-60 / 1.8 -2.5	17
RCA329	Carbide Seat Insert	15-30-60 / 2.0 -2.5	17
RCA330	Carbide Seat Insert	15-30-60 / 1.4 -2.5	17
RCA331	Carbide Seat Insert	15-30-60 / 1.4 -1.8	17
RCA332	Carbide Seat Insert	0-30-60 / 2.0 -2.8	17
RCA333	Carbide Seat Insert	5-30-60 / 2.0 -2.2 (Cummins NH Series Cylinder Head)	17
RCA337	Carbide Seat Insert	15-30-60 / 2.0mm (0.078) - 2.0mm (0.078")	18
RCA338	Carbide Seat Insert	15-30-60 / 2.0mm (0.078") - 4.46mm (0.180")	18
RCA348	Carbide Seat Insert	10-30-60 / 2.64mm - 2.16mm OFFSET Insert (For Detroit 53 Series Head)	18
RCA400	Carbide Seat Insert	30- 37.5 -60 / 1.4 -1.6	18
RCA401	Carbide Seat Insert	30- 37.5 -60 / 2.0 -1.6	18
RCA402	Carbide Seat Insert	30- 37.5 -60 / 1.4 -1.9	18
RCA403	Carbide Seat Insert	30- 37.5 -60 / 2.0 -2.0	18
RCA404	Carbide Seat Insert	18- 37.5 -52 / 0.6 -2.1	18
RCA405	Carbide Seat Insert	15- 37.5 -60 / 1.4 -1.6	18
RCA406	Carbide Seat Insert	20- 37.5 -52 / 1.2 -1.8	19
RCA407	Carbide Seat Insert	15- 37.5 -60 / 1.4 -1.6	19
RCA411	Carbide Seat Insert	37 degrees' / 9.3mm	19
RCA439	Carbide Seat Insert	30-40-60 top, seat width .080	19
RCA500	Carbide Seat Insert	15 degrees / 7.7mm.....	19
RCA501	Carbide Seat Insert	20 degrees / 8.8mm.....	19
RCA502	Carbide Seat Insert	30 degrees / 9.0mm.....	19
RCA503	Carbide Seat Insert	45 degrees / 8.9mm.....	19
RCA504	Carbide Seat Insert	45 degrees 15 ' / 8.0mm.....	19
RCA505	Carbide Seat Insert	60 degrees' / 8.1mm	20
RCA506	Carbide Seat Insert	70 degrees' / 16.8mm	20
RCA507	Carbide Seat Insert	75 degrees / 8.3mm.....	20
RCB508	Carbide Seat Insert	75 degrees' / 16.4mm	20



RCB509	Carbide Seat Insert	80 degrees' / 12.1mm	20
RCB510	Carbide Seat Insert	82 degrees' / 11.5mm	20
RCA511	Carbide Seat Insert	94 degrees 0.8 / 12mm (SHORT PROFILE)	20
RCA512	Carbide Seat Insert	94 degrees R 0.8 / 15.3mm	20
RCA513	Carbide Seat Insert	94-R0.5 / 2.5-6.5 (OFFSET FOR COUNTERBORING SMALL SEATS)	20
RCA521	Carbide Seat Insert	25 degrees' / 8.5mm	21
RCA522	Carbide Seat Insert	70 degrees' / 7.7mm	21
RCA524	Carbide Seat Insert	82 degrees' / 7.07mm	21
RCB600	Carbide Seat Insert	R2.5-38-45-60 / 2.5-2.4-1.00	21
RCB601	Carbide Seat Insert	R1-35-45-60-75 / 1.5-1.3-1.0-2.5	21
RCB602	Carbide Seat Insert	R1.0-35-45-56 / 2.0-1.3	21
RCB603	Carbide Seat Insert	R12 -45 degrees	21
RCB604	Carbide Seat Insert	R2-35-45-60-75-82 / 2.9-1.3-1.7-2.2	21
RCB605	Carbide Seat Insert	35-45-55-65-75 / 2.5-1.0-2.5-2.5	21
RCB606	Carbide Seat Insert	40-R1-45-55-65-75 / 1.5-1.3-1.0-2.5	22
RCB607	Carbide Seat Insert	R1.5-35-45-R12-75-R3.5 / 1.9-1.5-1.5-3.0	22
RCB608	Carbide Seat Insert	R1.5-35-45-R12-75-R3.5-45 / 1.9-1.5-1.0-3.0	22
RCB609	Carbide Seat Insert	R1.5-35-45-R12-75 / 1.9-1.5-2.5-3.0	22
RCB610	Carbide Seat Insert	R1.5-35-45-R12.2-85 / 1.8-1.5-1.5-3.0	22
RCA611	Carbide Seat Insert	R1.5-15-30-45-60-75 / 2.2-0.8	22
RCA612	Carbide Seat Insert	R1.2-25-45-65-75 / 1.2-0.8	22
RCA613	Carbide Seat Insert	R2-30-45-60-R7 / 1.9-0.8	22
RCA614	Carbide Seat Insert	R4 -15 / 5.52mm	22
RCA615	Carbide Seat Insert	R4 -30 / 5.70mm	23
RCA616	Carbide Seat Insert	R5 -15 / 5.00mm	23
RCA617	Carbide Seat Insert	R5 -30 / 6.00mm	23
RCA618	Carbide Seat Insert	R7 -15 / 4.4mm	23
RCA619	Carbide Seat Insert	R7 -30 / 4.4mm	23
RCB620	Carbide Seat Insert	R7 -15	23
RCB621	Carbide Seat Insert	75 - R7 / 12.0mm	23
RCB622	Carbide Seat Insert	80 - R7 / 9.00mm	23
RCA623	Carbide Seat Insert	R0.8-30-45-60-R13-R1.5 / 1.3-1.0	23
RCA624	Carbide Seat Insert	R1-32-45-60 / 1.3-0.8	24
RCA625	Carbide Seat Insert	30-R1-32-45-60 / 1.0-0.8	24
RCA626	Carbide Seat Insert	R1.5-30-45-60 / 1.6-1.0	24
RCA627	Carbide Seat Insert	R1.5-15-45-75 / 1.0-1.0	24
RCA628	Carbide Seat Insert	30-R1.5-15-45-75 / 1.0-1.0	24
RCA629	Carbide Seat Insert	R1.5-38-45-60 / 1.3-1.1	24
RCA630	Carbide Seat Insert	30-94-R1.5-38-45-60 / 1.3-1.1	24
RCA631	Carbide Seat Insert	R1.5-30-45-60 / 1.6-1.3	24



RCA632	Carbide Seat Insert	30-94-R1.5-30-45-60 / 1.6-1.3	24
RCA633	Carbide Seat Insert	30-45-60 / 2.0 -1.4	25
RCA634	Carbide Seat Insert	R1.6-30-45-60 / 1.6-1.5.....	25
RCA635	Carbide Seat Insert	30-94-R1.5-30-45-60 / 1.6-1.5	25
RCA636	Carbide Seat Insert	R1.5-32-45-60 / 1.6-1.0-1.0 (Offset Bit).....	25
RCA637	Carbide Seat Insert	R1.5-32-45-60 / 1.6-1.0-1.0	25
RCA638	Carbide Seat Insert	R1.5-30-45-75 / 1.6-1.0.....	25
RCA639	Carbide Seat Insert	30-R1.5-30-45-75 / 1.0-1.0	25
RCA640	Carbide Seat Insert	R1.5-32-45-60 / 1.6-1.2.....	25
RCA641	Carbide Seat Insert	R0.5-32-45-60 / 1.5-1.2.....	25
RCA642	Carbide Seat Insert	R1.5-20-45-60 / 1.0-1.0.....	26
RCA643	Carbide Seat Insert	30-R1.5-20-45-60 / 1.0-1.0	26
RCB644	Carbide Seat Insert	R3-30-R13-45-75-R3 / 2.5-1.2-1.2-3.0.....	26
RCB645	Carbide Seat Insert	R2-37-45-52-R7 / 1.5-0.8.....	26
RCB646	Carbide Seat Insert	R2 -35-45-65 / 2.0-1.4 - 0.8	26
RCB651	Carbide Seat Insert	30-94-30-45-60 / 3.1-1.5-3.0.....	26
RCB652	Carbide Seat Insert	30-94-32-45-60 / 1.0-0.8.....	26
RCB653	Carbide Seat Insert	30-45-60 / 1.2-1.0	26
RCB654	Carbide Seat Insert	45-91 / 19.6-6.3mm	26
RCA655	Carbide Seat Insert	R 5.00' / 16.00mm	27
RCA656	Carbide Seat Insert	30-45-R10 / 1.5-1.5.....	27
RCA700	Carbide Seat Insert	5-20-60 / 3.0mm - 2.5mm (.100") (Cat 3500 series).....	27
RCA723	Carbide Seat Insert	5-20-45 / 2.0mm - 2.0mm.....	27
RCA730	Carbide Seat Insert	5-20-45 / 2.0mm - 3.2mm (.126")	27
RCA731	Carbide Seat Insert	11-20-45 / 1.8mm - 3.8mm (.150").....	27
RCA756	Carbide Seat Insert	For CAT C9 Engines	27
RCA764	Carbide Seat Insert	15-40-60 top, seat width 1.27-1.65	27
RCA772	Carbide Seat Insert	15-25-45 top, seat width 1.50-2.35	27
RCA818	Carbide Seat Insert	15-25-70 with 70 degree radius top, - 1.5-3.0.....	28
RCA819	Carbide Seat Insert	15-40-70 with 70 degree radius top, - 1.0-2.5.....	28
Suggested Standard Carbide RCC Type Inserts for Large Seats Single Angle.....			28
RCC702	Carbide Seat Insert	20 degrees	28
RCC703	Carbide Seat Insert	30 degrees	28
RCC704	Carbide Seat Insert	45 degrees	28
RCC705	Carbide Seat Insert	94 degrees R 0.8 / 18mm	29
Suggested Standard Carbide RCC Type Inserts for Large Seats			29
RCC721	C Blank Carbide Seat Insert	0-20-60 / 1.8-2.0.....	29
RCC722	C Blank Carbide Seat Insert	0-20-75 / 2.0-2.0.....	29
RCC723	C Blank Carbide Seat Insert	5-20-45 / 2.0-2.0.....	29
RCC724	C Blank Carbide Seat Insert	10-20-75 / 2.0-2.3.....	30



RCC725 C Blank Carbide Seat Insert 0-20-60 / 1.8-2.5..... 30

RCC726 C Blank Carbide Seat Insert 5-20-75 / 2.0-2.5..... 30

RCC727 C Blank Carbide Seat Insert 15-20.25-60 / 3.0-2.5..... 30

RCC728 C Blank Carbide Seat Insert 15-20-60 / 2.8-2.66..... 30

RCC729 C Blank Carbide Seat Insert 5-20-45 / 3.0-3.0..... 30

RCC730 C Blank Carbide Seat Insert 5-20-45 / 2.0-3.2..... 30

RCC731 C Blank Carbide Seat Insert 11-20-45 / 1.8-3.8..... 30

RCC741 C Blank Carbide Seat Insert 15-30-60 / 2.0-4.6..... 30

RCC742 C Blank Carbide Seat Insert 15-30-45 / 2.0-1.8..... 31

RCC743 C Blank Carbide Seat Insert 15-30-15 / 2.0-2.2..... 31

RCC761 C Blank Carbide Seat Insert 30-45-60 / 1.6-1.9..... 31

RCC762 C Blank Carbide Seat Insert 30-45-60 / 2.0-2.5..... 31

RCC763 C Blank Carbide Seat Insert 30-45-60 / 2.2-2.0..... 31

RCC764 C Blank Carbide Seat Insert 15-30.50-60 / 2.0-6.4mm (.080”-.250”) White Superior Cylinder head..... 31

RCC765 C Blank Carbide Seat Insert 15-30.18-60 / 2.0-3.8mm (.080”-.150”) Waukesha Cylinder head..... 31

Tooling for Counterboring Small Diameter Valve Seat Pockets 32

6 mm Pilots Boring Combos 32

.375” Pilot Combos..... 32

SG Insert Cross Reference Chart..... 33

Custom Insert Profile Order Form 42

Rottler Special Profile Cutter Inserts Policy

Special Profile Cutter Inserts can be manufactured to your exact specifications and can include a combination of angles and radius blends. Special Profile Carbide Cutter Bits are generally considered to be "Customer Proprietary". These are uniquely numbered, exclusively for the ordering customer.

Suggested Carbide Cutting Inserts

See following pages for drawings of most popular Inserts.

Select the proper Insert base on the application RCA insert profiles are design for regular 3 angle seat profiles, make sure the that top angle will not go over the seat insert.

RCB inserts Profiles are design for a multiple angles and radius and is recommended for High performance profiles. RCC are large inserts and require T15 screw.

Automotive Import, Domestic and Diesel Inserts

Suggested 45 Degree Seat Inserts

NOTE: Orders of 20+ of the same RCA insert receive 10% discount. Orders of 50+ of the same RCA insert receive 20% discount. Does not apply to mix-and-match orders.

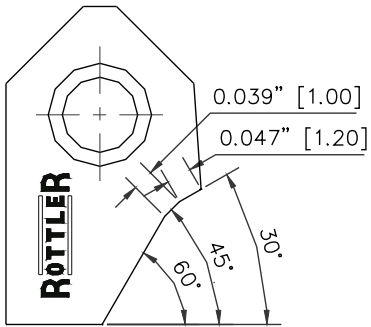
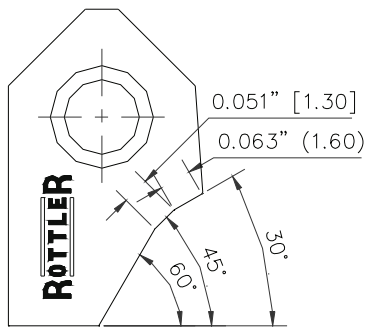
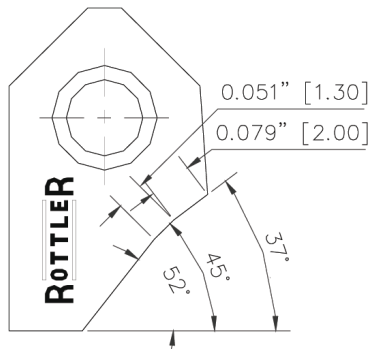
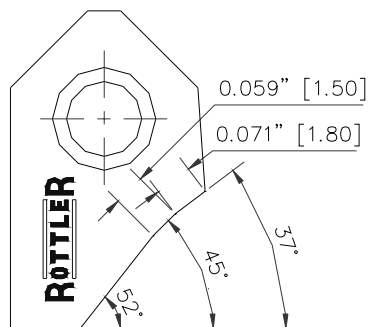
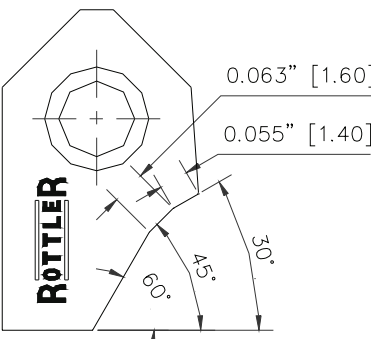
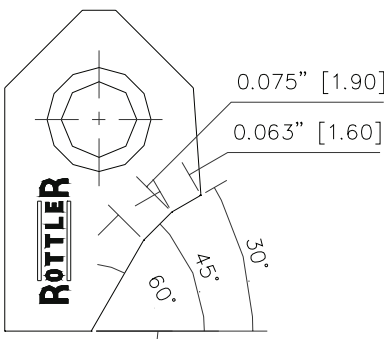
<p>RCA001 Carbide Seat Insert 30-45-60 / 1.2 -1.0</p> <p>RCA-001 (14 RC BIT KIT)</p> 	<p>RCA004 Carbide Seat Insert 30-45-60 / 1.6 -1.3</p> <p>RCA-004 (14 RC BIT KIT)</p> 	<p>RCA005 Carbide Seat Insert 37-45-52 / 2.0 -1.3</p> <p>RCA-005 (14 RC BIT KIT)</p> 
<p>RCA007 Carbide Seat Insert 37-45-52 / 1.8 -1.5</p> <p>RCA-007 (14 RC BIT KIT)</p> 	<p>RCA014 Carbide Seat Insert 30-45-60 / 1.4 -1.6</p> <p>RCA-014 (14 RC BIT KIT)</p> 	<p>RCA026 Carbide Seat Insert 30-45-60 / 1.6 -1.9</p> <p>RCA-026 (14 RC BIT KIT)</p> 

Suggested 30 Degree Seat Inserts

NOTE: Orders of 20+ of the same RCA insert receive 10% discount. Orders of 50+ of the same RCA insert receive 20% discount. Does not apply to mix-and-match orders.

<p>RCA301 Carbide Seat Insert 15-30-45 / 2.0 -1.3</p> <p>RCA-301 (14 RC BIT KIT)</p>	<p>RCA303 Carbide Seat Insert 15-30-45 / 1.4 -1.5</p> <p>RCA 303</p>	<p>RCA307 Carbide Seat Insert 15-30-45 / 1.8 -1.6</p> <p>RCA-307 (14 RC BIT KIT)</p>
---	---	---

RCA348 Carbide Seat Insert 10-30-60 / 2.64 - 2.16 OFFSET Insert (For Detroit 53 Series Cylinder Head)

RCA 348

Suggested 37.5 Degree Seat Inserts

NOTE: Orders of 20+ of the same RCA insert receive 10% discount. Orders of 50+ of the same RCA insert receive 20% discount. Does not apply to mix-and-match orders.

RCA401 Carbide Seat Insert 30-37.5-60 / 2.0 -1.6

RCA-401 (14 RC BIT KIT)

Suggested Straight Angle seat Inserts

NOTE: Orders of 20+ of the same RCA insert receive 10% discount. Orders of 50+ of the same RCA insert receive 20% discount. Does not apply to mix-and-match orders.

<p>RCA511 Carbide Seat Insert 94 degrees R 0.8 / 12mm (SHORT PROFILE for counterboring)</p> <p>RCA 511</p>	<p>RCA512 Carbide Seat Insert 94 degrees R 0.8 / 15.3mm (for counterboring)</p> <p>RCA 512</p>	<p>RCA513 Carbide Seat Insert 94-R0.5 / 2.5-6.5 (OFFSET FOR COUNTERBORING SMALL SEATS)</p> <p>RCA 513</p>
<p>RCA501 Carbide Seat Insert 20 degrees / 8.8mm</p> <p>RCA 501</p>	<p>RCA521 Carbide Seat Insert 25 degrees / 8.5mm</p> <p>RCA 521</p>	<p>RCA502 Carbide Seat Insert 30 degrees / 9.0mm</p> <p>RCA-502 (14 RC BIT KIT)</p>
<p>RCA503 Carbide Seat Insert 45 degrees / 8.9 mm</p> <p>RCA 503</p>	<p>RCB506 Carbide Seat Insert 70 degrees / 16.8mm</p> <p>RCB 506</p>	

Suggested 45 Degree Seat Inserts for Multi-Valves Cylinder Heads

NOTE: Orders of 20+ of the same RCA insert receive 10% discount. Orders of 50+ of the same RCA insert receive 20% discount. Does not apply to mix-and-match orders.

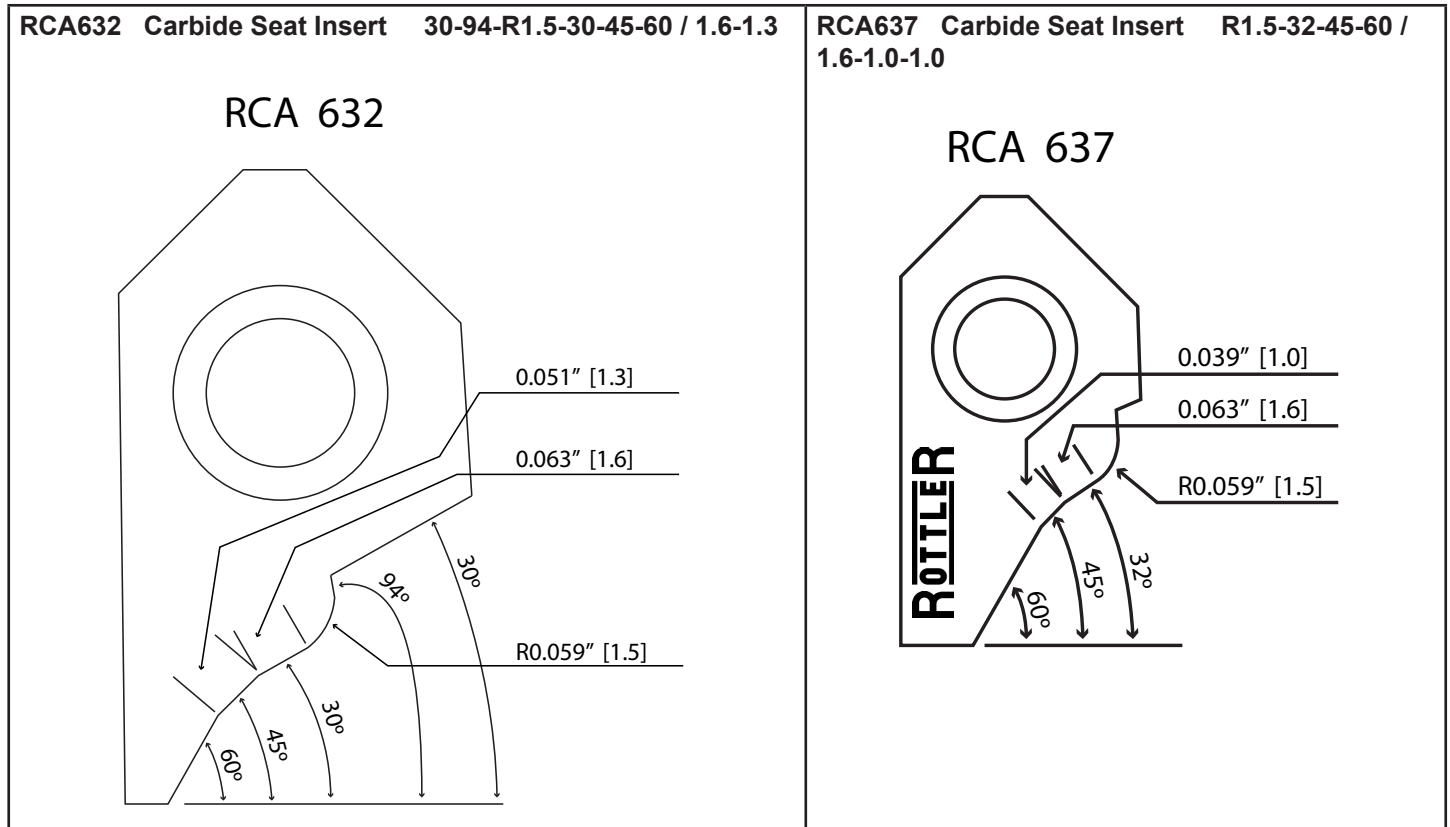

High Performance Inserts

NOTE: Orders of 20+ of the same RCA insert receive 10% discount. Orders of 50+ of the same RCA insert receive 20% discount. Does not apply to mix-and-match orders.

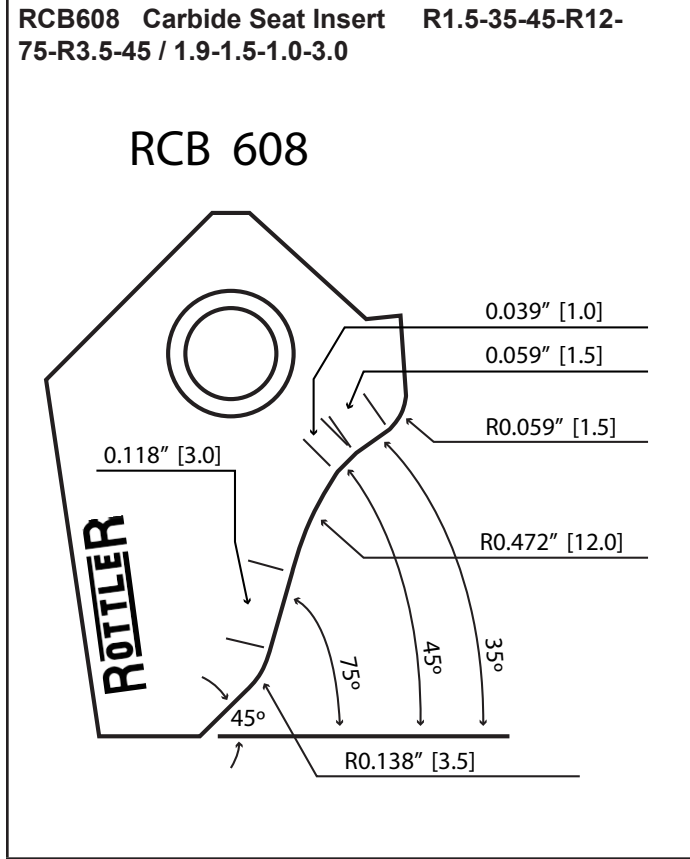
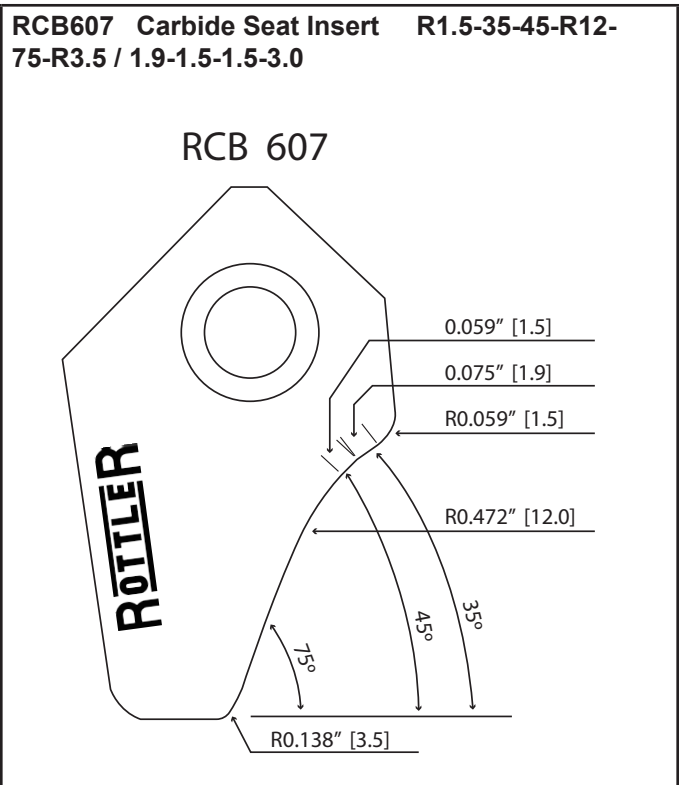
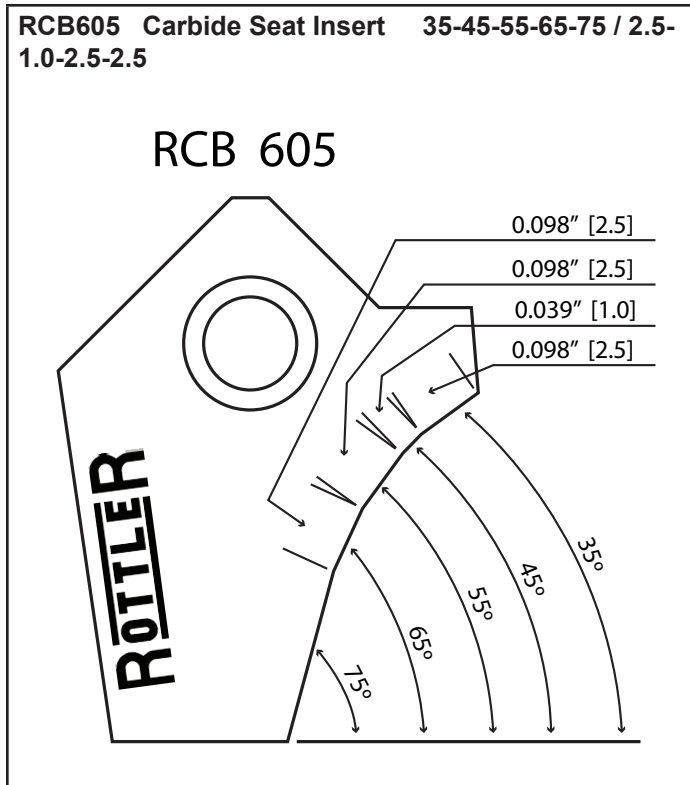

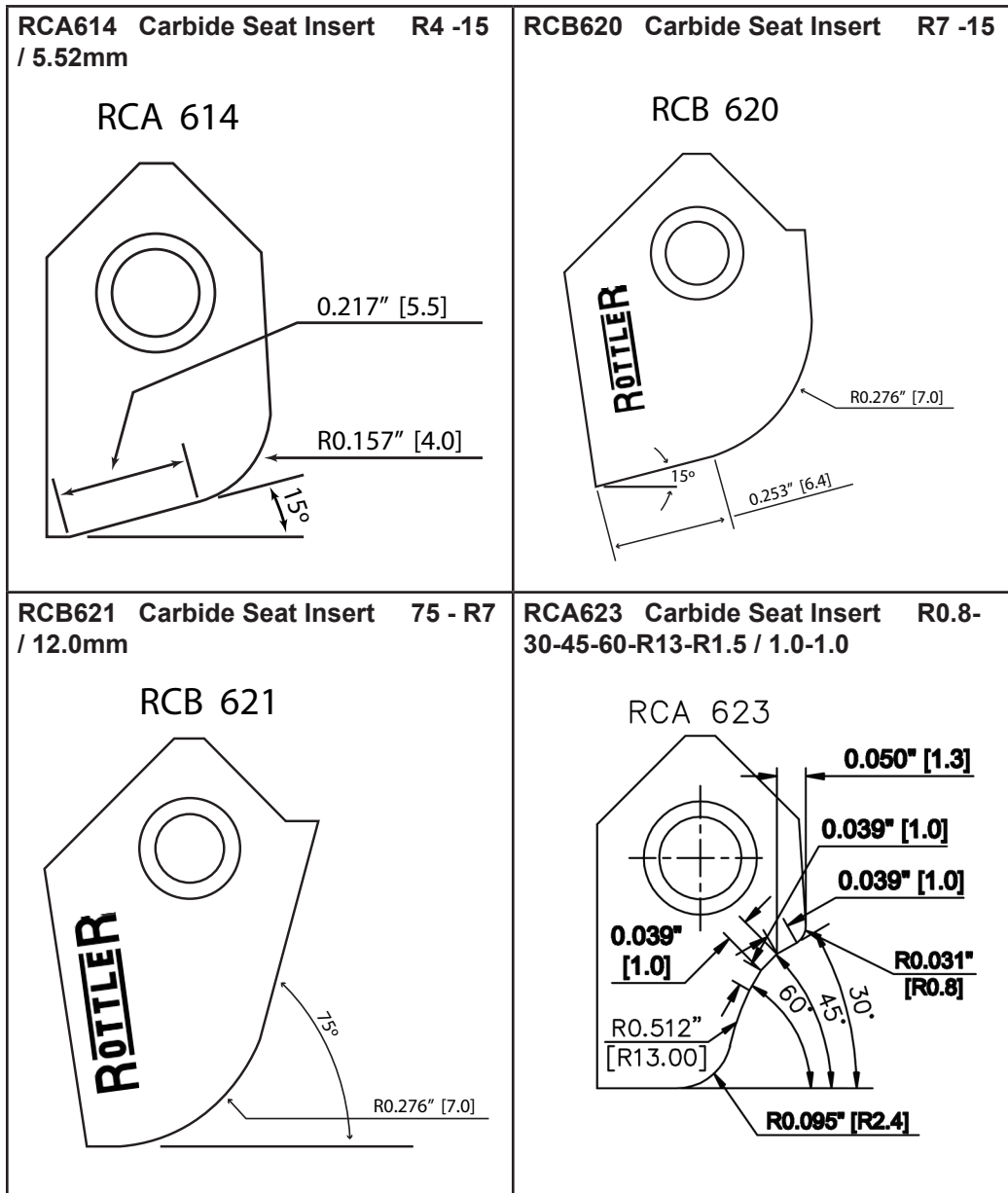

Harley Davidson Inserts

NOTE: Orders of 20+ of the same RCA insert receive 10% discount. Orders of 50+ of the same RCA insert receive 20% discount. Does not apply to mix-and-match orders.

<p>RCA626 Carbide Seat Insert R1.5-30-45-60 / 1.6-1.0</p> <p>RCA 626</p>	<p>RCA633 Carbide Seat Insert 30-45-60 / 2.0 -1.4</p> <p>RCA 633</p>	<p>RCA640 Carbide Seat Insert R1.5-32-45-60 / 1.6-1.2</p> <p>RCA 640</p>
---	---	---

Rottler Cutter Inserts Profiles

NOTE: Orders of 20+ of the same RCA insert receive 10% discount. Orders of 50+ of the same RCA insert receive 20% discount. Does not apply to mix-and-match orders.

<p>RCA001 Carbide Seat Insert 30-45-60 / 1.2 -1.0</p> <p>RCA-001 (14 RC BIT KIT)</p>	<p>RCA001-P Carbide Seat Insert 30-45-60 / 1.2 -1.0 Short Bottom Angle (Perkins Requirements)</p> <div style="border: 2px solid black; padding: 10px; text-align: center;"> <p>Image Currently Unavailable</p> </div>	<p>RCA002 Carbide Seat Insert 30-45-60 / 2.0 -1.0</p> <p>RCA-002</p>
---	--	---

<p>RCA003 Carbide Seat Insert 30-45-60 / 1.2 -1.3 RCA-003</p>	<p>RCA004 Carbide Seat Insert 30-45-60 / 1.6 -1.3 RCA-004 (14 RC BIT KIT)</p>	<p>RCA005 Carbide Seat Insert 37-45-52 / 2.0 -1.3 RCA-005 (14 RC BIT KIT)</p>
<p>RCA006 Carbide Seat Insert 30-45-52 / 2.0 -1.3 RCA-006</p>	<p>RCA007 Carbide Seat Insert 37-45-52 / 1.8 -1.5 RCA-007 (14 RC BIT KIT)</p>	<p>RCA008 Carbide Seat Insert 15-45-60 / 1.8 -1.5 RCA-008</p>
<p>RCA009 Carbide Seat Insert 30-45-52 / 1.8 -1.5 RCA-009</p>	<p>RCA010 Carbide Seat Insert 30-45-60 / 2.0 -1.5 RCA-010</p>	<p>RCA011 Carbide Seat Insert 30-45-60 / 3.0 -1.5 RCA-011</p>

<p>RCA012 Carbide Seat Insert 30-45-52 / 1.2 -1.6</p> <p>RCA-012</p>	<p>RCA013 Carbide Seat Insert 30-45-60 / 1.2 -1.6</p> <p>RCA-013</p>	<p>RCA014 Carbide Seat Insert 30-45-60 / 1.4 -1.6</p> <p>RCA-014 (14 RC BIT KIT)</p>
<p>RCA015 Carbide Seat Insert 15-45-60 / 1.6 -1.6</p> <p>RCA-015</p>	<p>RCA016 Carbide Seat Insert 30-45-52 / 1.6 -1.6</p> <p>RCA-016</p>	<p>RCA017 Carbide Seat Insert 30-45-60 / 2.0 -2.2</p> <p>RCA-017</p>
<p>RCA018 Carbide Seat Insert 30-45-52 / 1.8 -1.6</p> <p>RCA-018</p>	<p>RCA019 Carbide Seat Insert 15-45-60 / 2.0 -1.6</p> <p>RCA-019</p>	<p>RCA020 Carbide Seat Insert 30-45-52 / 2.0 -1.6</p> <p>RCA-020</p>

<p>RCA021 Carbide Seat Insert 30-45-60 / 2.0 -1.6</p> <p>RCA-021</p>	<p>RCA022 Carbide Seat Insert 30-45-60 / 3.0 -1.6</p> <p>RCA-022</p>	<p>RCA023 Carbide Seat Insert 30-45-60 / 3.0 -1.8</p> <p>RCA-023</p>
<p>RCA024 Carbide Seat Insert 30-45-52 / 1.2 -1.9</p> <p>RCA-024</p>	<p>RCA025 Carbide Seat Insert 30-45-60 / 1.2 -1.9 (Caterpillar 3500E Intake seat Profile)</p> <p>RCA-025</p>	<p>RCA026 Carbide Seat Insert 30-45-60 / 1.6 -1.9</p> <p>RCA-026 (14 RC BIT KIT)</p>
<p>RCA027 Carbide Seat Insert 30-45-52 / 1.8 -1.9</p> <p>RCA-027</p>	<p>RCA028 Carbide Seat Insert 30-45-52 / 2.0 -1.9</p> <p>RCA-028</p>	<p>RCA029 Carbide Seat Insert 30-45-60 / 2.0 -1.9</p> <p>RCA-029</p>

<p>RCA030 Carbide Seat Insert 30-45-70 / 1.6 -2.0</p> <p>RCA-030</p>	<p>RCA031 Carbide Seat Insert 30-45-75 / 1.6 -2.0</p> <p>RCA-031</p>	<p>RCA032 Carbide Seat Insert 30-45-60 / 0.6 -2.2</p> <p>RCA-032</p>
<p>RCA033 Carbide Seat Insert 30-45-60 / 2.0 -2.3</p> <p>RCA-033</p>	<p>RCA034 Carbide Seat Insert 30-45-60 / 2.0 -2.5</p> <p>RCA-034</p>	<p>RCA035 Carbide Seat Insert 25-45-60 / 1.4 -1.0</p> <p>RCA-035</p>
<p>RCA036 Carbide Seat Insert 25-45-60 / 1.8 -1.0</p> <p>RCA-036</p>	<p>RCA037 Carbide Seat Insert 35-45-52 / 1.6 -1.0</p> <p>RCA-037</p>	<p>RCA038 Carbide Seat Insert 35-45-55 / 1.6 -1.0</p> <p>RCA-038</p>

<p>RCA039 Carbide Seat Insert 35-45-60 / 1.6 -1.0</p> <p>RCA-039</p>	<p>RCA040 Carbide Seat Insert 30-45-60 / 2.0 -1.3</p> <p>RCA-040</p>	<p>RCA041 Carbide Seat Insert 30-45-60 / 1.0 -1.3</p> <p>RCA-041</p>
<p>RCA042 Carbide Seat Insert 30-45-60 / 1.0 -1.4</p> <p>RCA-042</p>	<p>RCA043 Carbide Seat Insert 30-45-60 / 1.8 -1.5</p> <p>RCA-043</p>	<p>RCA044 Carbide Seat Insert 30-45-60 / 1.4 -1.5</p> <p>RCA-044</p>
<p>RCA045 Carbide Seat Insert 25-45-60 / 1.4 -1.6</p> <p>RCA-045</p>	<p>RCA046 Carbide Seat Insert 25-45-60 / 1.8 -1.6</p> <p>RCA-046</p>	<p>RCA047 Carbide Seat Insert 30-45-60 / 1.0 -1.6</p> <p>RCA-047</p>

<p>RCA048 Carbide Seat Insert 30-45-60 / 2.0 -1.7</p> <p>RCA-048</p>	<p>RCA049 Carbide Seat Insert 30-45-60 / 1.6 -1.8</p> <p>RCA-049</p>	<p>RCA050 Carbide Seat Insert 30-45-52 / 0.8 -1.9</p> <p>RCA-050</p>
<p>RCA051 Carbide Seat Insert 25-45-60 / 1.4 -2.0</p> <p>RCA-051</p>	<p>RCA052 Carbide Seat Insert 25-45-60 / 1.8 -2.0</p> <p>RCA-052</p>	<p>RCA053 Carbide Seat Insert 30-45-60 / 1.2 -2.0</p> <p>RCA-053</p>
<p>RCA054 Carbide Seat Insert 25-45-60 / 1.4 -2.5</p> <p>RCA-054</p>	<p>RCA055 Carbide Seat Insert 25-45-60 / 1.8 -2.5</p> <p>RCA-055</p>	<p>RCA056 Carbide Seat Insert 30-45-60 / 1.8 -1.0</p> <p>RCA-056</p>

<p>RCA057 Carbide Seat Insert 37-45-52 / 2.0 -1.0</p> <p>RCA-057</p>	<p>RCA058 Carbide Seat Insert 25-45-52 / 1.9 -1.6</p> <p>RCA 058</p>	<p>RCA059 Carbide Seat Insert 25-45-52 / 2.3 -1.7</p> <p>RCA 059</p>
<p>RCA077 Carbide Seat Insert 25-45-60 / 1.4-1.2</p> <p>RCA-077</p>	<p>RCA300 Carbide Seat Insert 15-30-45 / 1.0 -1.3</p> <p>RCA-300</p>	<p>RCA301 Carbide Seat Insert 15-30-45 / 2.0 -1.3</p> <p>RCA-301 (14 RC BIT KIT)</p>
<p>RCA302 Carbide Seat Insert 15-30-60 / 2.0 -1.3</p> <p>RCA-302</p>	<p>RCA303 Carbide Seat Insert 15-30-45 / 1.4 -1.5</p> <p>RCA 303</p>	<p>RCA304 Carbide Seat Insert 15-30-45 / 1.8 -1.5</p> <p>RCA-304</p>

<p>RCA305 Carbide Seat Insert 15-30-60 / 2.0 -1.5</p> <p>RCA-305</p>	<p>RCA306 Carbide Seat Insert 15-30-45 / 1.2 -1.6</p> <p>RCA-306</p>	<p>RCA307 Carbide Seat Insert 15-30-45 / 1.8 -1.6</p> <p>RCA-307 (14 RC BIT KIT)</p>
<p>RCA308 Carbide Seat Insert 15-30-52 / 1.8 -1.6</p> <p>RCA-308</p>	<p>RCA309 Carbide Seat Insert 15-30-45 / 2.0 -1.6</p> <p>RCA-309</p>	<p>RCA310 Carbide Seat Insert 15-30-60 / 2.0 -1.6</p> <p>RCA-310</p>
<p>RCA311 Carbide Seat Insert 15-30-60 / 2.2 -1.6</p> <p>RCA-311</p>	<p>RCA312 Carbide Seat Insert 15-30-45 / 2.0 -1.8</p> <p>RCA-312</p>	<p>RCA313 Carbide Seat Insert 15-30-45 / 1.0 -1.9</p> <p>RCA-313</p>

<p>RCA314 Carbide Seat Insert 15-30-60 / 2.0 -1.9</p> <p>RCA-314</p>	<p>RCA315 Carbide Seat Insert 15-30-45 / 1.2 -2.0 (Caterpillar 3500E Exhaust seat Profile)</p> <p>RCA-315</p>	<p>RCA316 Carbide Seat Insert 15-30-45 / 2.0 -2.0</p> <p>RCA-316</p>
<p>RCA317 Carbide Seat Insert 15-30-60 / 2.0 -2.2</p> <p>RCA-317</p>	<p>RCA318 Carbide Seat Insert 20-30-45 / 3.0 -3.8</p> <p>RCA-318</p>	<p>RCA321 Carbide Seat Insert 20-30-52 / 1.6 -1.0</p> <p>RCA-321</p>
<p>RCA322 Carbide Seat Insert 0-30-60 / 2.0 -1.5</p> <p>RCA-322</p>	<p>RCA323 Carbide Seat Insert 15-30-60 / 1.8 -1.5</p> <p>RCA-323</p>	<p>RCA324 Carbide Seat Insert 15-30-60 / 2.2 -1.5</p> <p>RCA-324</p>

<p>RCA325 Carbide Seat Insert 20-30-60 / 3.0 -1.5</p> <p>RCA-325</p>	<p>RCA326 Carbide Seat Insert 15-30-60 / 1.4 -2.0</p> <p>RCA-326</p>	<p>RCA327 Carbide Seat Insert 15-30-60 / 1.8 -2.0</p> <p>RCA-327</p>
<p>RCA328 Carbide Seat Insert 15-30-60 / 1.8 -2.5</p> <p>RCA-328</p>	<p>RCA329 Carbide Seat Insert 15-30-60 / 2.0 -2.5</p> <p>RCA-329</p>	<p>RCA330 Carbide Seat Insert 15-30-60 / 1.4 -2.5</p> <p>RCA-330</p>
<p>RCA331 Carbide Seat Insert 15-30-60 / 1.4 -1.8</p> <p>RCA-331</p>	<p>RCA332 Carbide Seat Insert 0-30-60 / 2.0 -2.8</p> <p>RCA-332</p>	<p>RCA333 Carbide Seat Insert 5-30-60 / 2.0 -2.2 (Cummins NH Series Cylinder Head)</p> <p>RCA-333</p>

<p>RCA337 Carbide Seat Insert 15-30-60 / 2.0mm (0.078) - 2.0mm (0.078")</p> <p>RCA-337</p>	<p>RCA338 Carbide Seat Insert 15-30-60 / 2.0mm (0.078") - 4.46mm (0.180")</p> <p>RCA-338</p>	<p>RCA348 Carbide Seat Insert 10-30-60 / 2.64mm - 2.16mm OFFSET Insert (For Detroit 53 Series Head)</p> <p>RCA 348</p>
<p>RCA400 Carbide Seat Insert 30-37.5 -60 / 1.4 -1.6</p> <p>RCA-400</p>	<p>RCA401 Carbide Seat Insert 30-37.5 -60 / 2.0 -1.6</p> <p>RCA-401 (14 RC BIT KIT)</p>	<p>RCA402 Carbide Seat Insert 30-37.5 -60 / 1.4 -1.9</p> <p>RCA-402</p>
<p>RCA403 Carbide Seat Insert 30-37.5 -60 / 2.0 -2.0</p> <p>RCA-403</p>	<p>RCA404 Carbide Seat Insert 18-37.5 -52 / 0.6 -2.1</p> <p>RCA-404</p>	<p>RCA405 Carbide Seat Insert 15-37.5 -60 / 1.4 -1.6</p> <p>RCA-405</p>

<p>RCA406 Carbide Seat Insert 20-37.5 -52 / 1.2 -1.8</p> <p>RCA-406</p>	<p>RCA407 Carbide Seat Insert 15-37.5 -60 / 1.4 -1.6</p> <p>RCA-407</p>	<p>RCA411 Carbide Seat Insert 37 degrees' / 9.3mm</p> <p>RCA 411</p>
<p>RCA439 Carbide Seat Insert 30-40-60 top, seat width .080</p> <div style="border: 1px solid black; padding: 10px; text-align: center;"> <p>Image Currently Unavailable</p> </div>	<p>RCA500 Carbide Seat Insert 15 degrees / 7.7mm</p> <p>RCA 500</p>	<p>RCA501 Carbide Seat Insert 20 degrees / 8.8mm</p> <p>RCA 501</p>
<p>RCA502 Carbide Seat Insert 30 degrees / 9.0mm</p> <p>RCA-502 (14 RC BIT KIT)</p>	<p>RCA503 Carbide Seat Insert 45 degrees / 8.9mm</p> <p>RCA 503</p>	<p>RCA504 Carbide Seat Insert 45 degrees 15' / 8.0mm</p> <p>RCA-504</p>

<p>RCA505 Carbide Seat Insert 60 degrees' / 8.1mm</p> <p>RCA 505</p>	<p>RCA506 Carbide Seat Insert 70 degrees' / 16.8mm</p> <p>Image Currently Unavailable</p>	<p>RCA507 Carbide Seat Insert 75 degrees / 8.3mm</p> <p>RCA 507</p>
<p>RCB508 Carbide Seat Insert 75 degrees' / 16.4mm</p> <p>RCB 508</p>	<p>RCB509 Carbide Seat Insert 80 degrees' / 12.1mm</p> <p>RCB 509</p>	<p>RCB510 Carbide Seat Insert 82 degrees' / 11.5mm</p> <p>RCB-510</p>
<p>RCA511 Carbide Seat Insert 94 degrees 0.8 / 12mm (SHORT PROFILE)</p> <p>RCA 511</p>	<p>RCA512 Carbide Seat Insert 94 degrees R 0.8 / 15.3mm</p> <p>RCA 512</p>	<p>RCA513 Carbide Seat Insert 94-R0.5 / 2.5-6.5 (OFFSET FOR COUNTERBORING SMALL SEATS)</p> <p>RCA 513</p>

<p>RCA521 Carbide Seat Insert 25 degrees' / 8.5mm</p> <p>RCA 521</p>	<p>RCA522 Carbide Seat Insert 70 degrees' / 7.7mm</p> <p>RCA-522</p>	<p>RCA524 Carbide Seat Insert 82 degrees' / 7.07mm</p> <p>RCA 524</p>
<p>RCB600 Carbide Seat Insert R2.5-38-45-60 / 2.5-2.4-1.00</p> <p>RCB 600</p>	<p>RCB601 Carbide Seat Insert R1-35-45-60-75 / 1.5-1.3-1.0-2.5</p> <p>RCB 601</p>	<p>RCB602 Carbide Seat Insert R1.0-35-45-56 / 2.0-1.3</p> <p>RCB 602</p>
<p>RCB603 Carbide Seat Insert R12-45 degrees</p> <p>RCB 603</p>	<p>RCB604 Carbide Seat Insert R2-35-45-60-75-82 / 2.9-1.3-1.7-2.2</p> <p>RCB 604</p>	<p>RCB605 Carbide Seat Insert 35-45-55-65-75 / 2.5-1.0-2.5-2.5</p> <p>RCB 605</p>

<p>RCB606 Carbide Seat Insert 40- R1-45-55-65-75 / 1.5-1.3-1.0-2.5</p> <p>RCB 606</p>	<p>RCB607 Carbide Seat Insert R1.5-35-45-R12-75-R3.5 / 1.9-1.5-1.5-3.0</p> <p>RCB 607</p>	<p>RCB608 Carbide Seat Insert R1.5-35-45-R12-75-R3.5-45 / 1.9-1.5-1.0-3.0</p> <p>RCB 608</p>
<p>RCB609 Carbide Seat Insert R1.5-35-45-R12-75 / 1.9-1.5-2.5-3.0</p> <p>RCB 609</p>	<p>RCB610 Carbide Seat Insert R1.5-35-45-R12.2-85 / 1.8-1.5-1.5-3.0</p> <p>RCB 610</p>	<p>RCA611 Carbide Seat Insert R1.5-15-30-45-60-75 / 2.2-0.8</p> <p>RCA-611</p>
<p>RCA612 Carbide Seat Insert R1.2-25-45-65-75 / 1.2-0.8</p> <p>RCA-612</p>	<p>RCA613 Carbide Seat Insert R2- 30-45-60-R7 / 1.9-0.8</p> <p>RCA-613</p>	<p>RCA614 Carbide Seat Insert R4 -15 / 5.52mm</p> <p>RCA 614</p>

<p>RCA615 Carbide Seat Insert R4 -30 / 5.70mm</p>	<p>RCA616 Carbide Seat Insert R5 -15 / 5.00mm</p>	<p>RCA617 Carbide Seat Insert R5 -30 / 6.00mm</p>
<p>RCA618 Carbide Seat Insert R7 -15 / 4.4mm</p>	<p>RCA619 Carbide Seat Insert R7 -30 / 4.4mm</p>	<p>RCB620 Carbide Seat Insert R7 -15</p>
<p>RCB621 Carbide Seat Insert R7 / 12.0mm</p>	<p>RCB622 Carbide Seat Insert R7 / 9.00mm</p>	<p>RCA623 Carbide Seat Insert R0.8-30-45-60-R13-R1.5 / 1.3-1.0</p>

<p>RCA624 Carbide Seat Insert R1-32-45-60 / 1.3-0.8</p> <p>RCA 624</p>	<p>RCA625 Carbide Seat Insert 30-R1-32-45-60 / 1.0-0.8</p> <p>RCA 625</p>	<p>RCA626 Carbide Seat Insert R1.5-30-45-60 / 1.6-1.0</p> <p>RCA 626</p>
<p>RCA627 Carbide Seat Insert R1.5-15-45-75 / 1.0-1.0</p> <p>RCA 627</p>	<p>RCA628 Carbide Seat Insert 30-R1.5-15-45-75 / 1.0-1.0</p> <p>RCA 628</p>	<p>RCA629 Carbide Seat Insert R1.5-38-45-60 / 1.3-1.1</p> <p>RCA 629</p>
<p>RCA630 Carbide Seat Insert 30-94-R1.5-38-45-60 / 1.3-1.1</p> <p>RCA 630</p>	<p>RCA631 Carbide Seat Insert R1.5-30-45-60 / 1.6-1.3</p> <p>RCA 631</p>	<p>RCA632 Carbide Seat Insert 30-94-R1.5-30-45-60 / 1.6-1.3</p> <p>RCA 632</p>

<p>RCA633 Carbide Seat Insert 30-45-60 / 2.0 -1.4</p> <p>RCA 633</p>	<p>RCA634 Carbide Seat Insert R1.6-30-45-60 / 1.6-1.5</p> <p>RCA 634</p>	<p>RCA635 Carbide Seat Insert 30-94-R1.5-30-45-60 / 1.6-1.5</p> <p>RCA 635</p>
<p>RCA636 Carbide Seat Insert R1.5-32-45-60 / 1.6-1.0-1.0 (Offset Bit)</p> <p>RCA 636</p>	<p>RCA637 Carbide Seat Insert R1.5-32-45-60 / 1.6-1.0-1.0</p> <p>RCA 637</p>	<p>RCA638 Carbide Seat Insert R1.5-30-45-75 / 1.6-1.0</p> <p>RCA 638</p>
<p>RCA639 Carbide Seat Insert 30-R1.5-30-45-75 / 1.0-1.0</p> <p>RCA 639</p>	<p>RCA640 Carbide Seat Insert R1.5-32-45-60 / 1.6-1.2</p> <p>RCA 640</p>	<p>RCA641 Carbide Seat Insert R0.5-32-45-60 / 1.5-1.2</p> <p>RCA 641</p>

<p>RCA642 Carbide Seat Insert R1.5-20-45-60 / 1.0-1.0</p> <p>RCA 642</p>	<p>RCA643 Carbide Seat Insert 30- R1.5-20-45-60 / 1.0-1.0</p> <p>RCA 643</p>	<p>RCB644 Carbide Seat Insert R3- 30-R13-45-75-R3 / 2.5-1.2-1.2-3.0</p> <p>RCB 644</p>
<p>RCB645 Carbide Seat Insert R2- 37-45-52-R7 / 1.5-0.8</p> <div style="border: 1px solid black; padding: 10px; text-align: center;"> <p>Image Currently Unavailable</p> </div>	<p>RCB646 Carbide Seat Insert R2 -35-45-65 / 2.0-1.4 - 0.8</p> <p>RCB 646</p>	<p>RCB651 Carbide Seat Insert 30- 94-30-45-60 / 3.1-1.5-3.0</p> <p>RCB 651</p>
<p>RCB652 Carbide Seat Insert 30- 94-32-45-60 / 1.0-0.8</p> <p>RCB 652</p>	<p>RCB653 Carbide Seat Insert 30- 45-60 / 1.2-1.0</p> <p>RCB 653</p>	<p>RCB654 Carbide Seat Insert 45- 91 / 19.6-6.3mm</p> <p>RCB 654</p>

<p>RCA655 Carbide Seat Insert R 5.00' / 16.00mm</p> <p>RCA 655</p>	<p>RCA656 Carbide Seat Insert 30- 45-R10 / 1.5-1.5</p> <p>RCA 656</p>	<p>RCA700 Carbide Seat Insert 5-20-60 / 3.0mm - 2.5mm (.100") (Cat 3500 series)</p> <p>RCA 700</p>
<p>RCA723 Carbide Seat Insert 5-20-45 / 2.0mm - 2.0mm</p> <p>RCA 723</p>	<p>RCA730 Carbide Seat Insert 5-20-45 / 2.0mm - 3.2mm (.126")</p> <p>RCA 730</p>	<p>RCA731 Carbide Seat Insert 11- 20-45 / 1.8mm - 3.8mm (.150")</p> <p>RCA 731</p>
<p>RCA756 Carbide Seat Insert For CAT C9 Engines</p> <p>RCA 756</p>	<p>RCA764 Carbide Seat Insert 15- 40-60 top, seat width 1.27-1.65</p> <p>RCA-764</p>	<p>RCA772 Carbide Seat Insert 15- 25-45 top, seat width 1.50-2.35</p> <p>RCA-772</p>

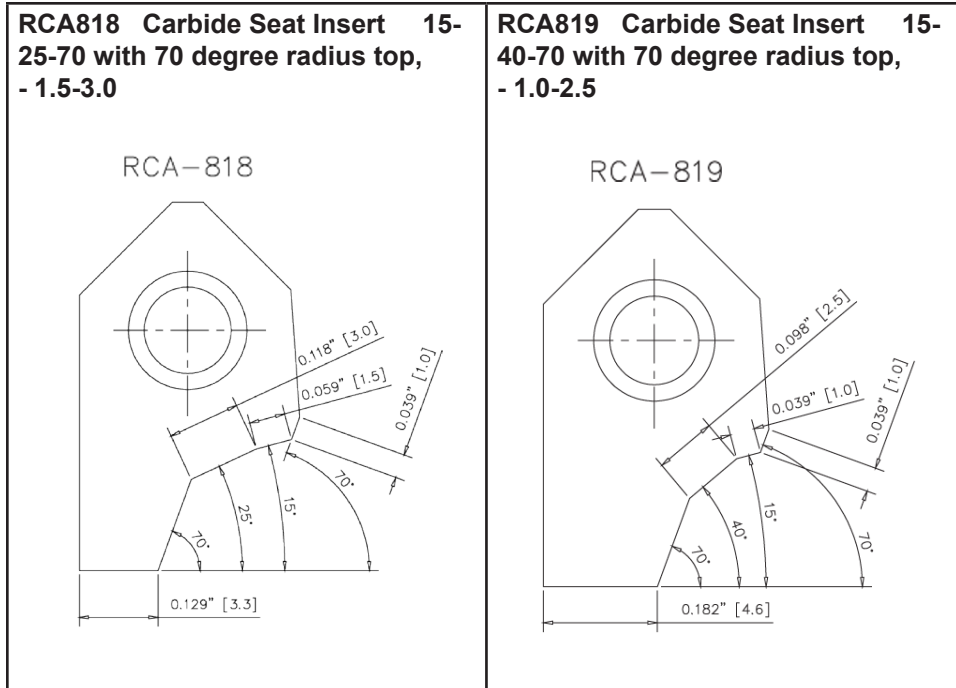

Suggested Standard Carbide RCC Type Inserts for Large Seats Single Angle

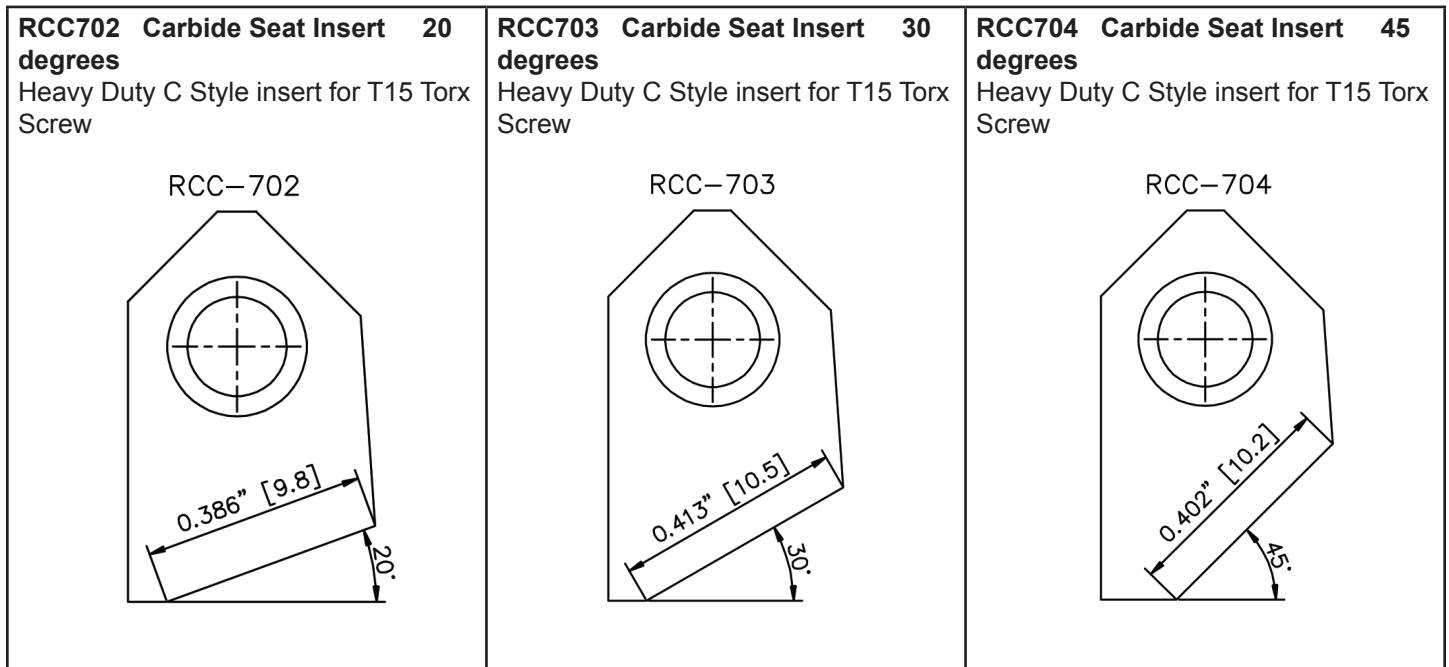

RCC705 Carbide Seat Insert 94 degrees R 0.8 / 18mm
 Heavy Duty C Style insert for T15 Torx Screw For counterboring.

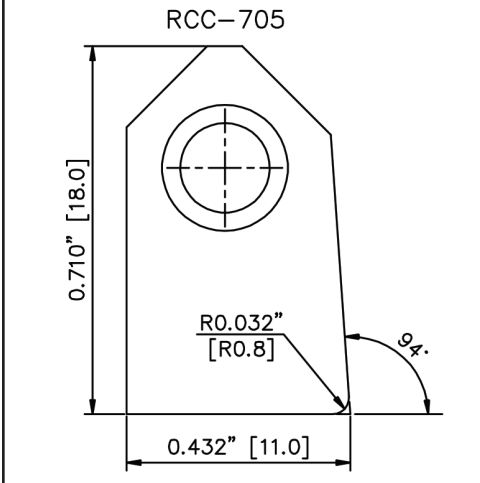

Suggested Standard Carbide RCC Type Inserts for Large Seats

<p>RCC721 C Blank Carbide Seat Insert 0-20-60 / 1.8-2.0</p> <p>RCC-721</p>	<p>RCC722 C Blank Carbide Seat Insert 0-20-75 / 2.0-2.0</p> <p>RCC-722</p>	<p>RCC723 C Blank Carbide Seat Insert 5-20-45 / 2.0-2.0</p> <p>RCC-723</p>
---	---	---



<p>RCC724 C Blank Carbide Seat Insert 10-20-75 / 2.0-2.3</p> <p>RCC-724</p>	<p>RCC725 C Blank Carbide Seat Insert 0-20-60 / 1.8-2.5</p> <p>RCC-725</p>	<p>RCC726 C Blank Carbide Seat Insert 5-20-75 / 2.0-2.5</p> <p>RCC-726</p>
<p>RCC727 C Blank Carbide Seat Insert 15-20.25-60 / 3.0-2.5</p> <p>RCC-727</p>	<p>RCC728 C Blank Carbide Seat Insert 15-20-60 / 2.8-2.66</p> <p>RCC-728</p>	<p>RCC729 C Blank Carbide Seat Insert 5-20-45 / 3.0-3.0</p> <p>RCC-729</p>
<p>RCC730 C Blank Carbide Seat Insert 5-20-45 / 2.0-3.2</p> <p>RCC-730</p>	<p>RCC731 C Blank Carbide Seat Insert 11-20-45 / 1.8-3.8</p> <p>RCC-731</p>	<p>RCC741 C Blank Carbide Seat Insert 15-30-60 / 2.0-4.6</p> <p>RCC-741</p>

<p>RCC742 C Blank Carbide Seat Insert 15-30-45 / 2.0-1.8</p> <p>RCC-742</p> <p>0.071" [1.8] 0.079" [2.0]</p>	<p>RCC743 C Blank Carbide Seat Insert 15-30-15 / 2.0-2.2</p> <p>RCC-743</p> <p>0.087" [2.2] 0.079" [2.0]</p>	<p>RCC761 C Blank Carbide Seat Insert 30-45-60 / 1.6-1.9</p> <p>RCC-761</p> <p>0.075" [1.9] 0.063" [1.6]</p>
<p>RCC762 C Blank Carbide Seat Insert 30-45-60 / 2.0-2.5</p> <p>RCC-762</p> <p>0.098" [2.5] 0.079" [2.0]</p>	<p>RCC763 C Blank Carbide Seat Insert 30-45-60 / 2.2-2.0</p> <p>RCC-763</p> <p>0.079" [2.0] 0.087" [2.2]</p>	<p>RCC764 C Blank Carbide Seat Insert 15-30.50-60 / 2.0-6.4mm (.080"-.250") White Superior Cylinder head</p> <p>RCC-764</p> <p>0.250" [6.4] 0.080" [2.0]</p>
<p>RCC765 C Blank Carbide Seat Insert 15-30.18-60 / 2.0-3.8mm (.080"-.150") Waukesha Cylinder head</p> <p>RCC-765</p> <p>0.150" [3.8] 0.080" [2.0]</p>		



Tooling for Counterboring Small Diameter Valve Seat Pockets

Rottler offers two options for counterboring small diameter valve seat pockets:

6 mm Pilots Boring Combos

<p>BH600R1 Mini Spherical Toolholder TH2000-00 Tip Holder RT211 Triangular Insert Bore diameter: 1.055" – 1.400" (26.80 mm – 35.55 mm)</p> 	<p>BH600R1 Mini Spherical Toolholder TH1999 Tip Holder RCA513 Seat Cutting Insert Bore diameter: .800" – 1.200" (20.80 mm – 30.48 mm)</p> 
---	--

.375" Pilot Combos

<p>BH375R1 Spherical Toolholder TH2000-00 Tip Holder RT211 Triangular Insert Bore diameter: 1.270" – 1.580" (32.26 mm – 40.15 mm)</p> 	<p>BH375R1 Spherical Toolholder TH1999 Tip Holder RCA513 Seat Cutting Insert Bore diameter: 1.000" – 1.280" (25.42 mm – 32.51 mm)</p> 
--	--

Rottler can also provide Fixed Milling Heads to cut valve seat pockets. They are available in fixed diameters from 1.000" to 2.250" in .0625" increments



SG Insert Cross Reference Chart

Rottler #	Newen #	K-line	Goodson	Serdi old #	Sunnen #	Other Ref #	Serdi-Italy	R-1 ref of	Top-seat-Throat Angle	Top-seat width	Regis #
RCA 001	A1-4028	KL-9401-11	FT-45039V1	10F45X60-A1	A 05424			A/B style tips	30-45-60	1.2 -1.0	R-11
RCA 002	A1-4303		FT-45059V3	10K45X60-A1	A -09040				30-45-60	2.0 -1.0	
RCA 003	A1-4221		FT-45051V4	13F45X60-A1	A 08224				30-45-60	1.2 -1.3	
RCA 004	A1-4480			13H45X60-A1	A 09932				30-45-60	1.6 -1.3	
RCA 005	A1-4033	KL-9401-28	FT-45051X1	13K45G52-A1	A 05940				37-45-52	2.0 -1.3	R-26
RCA 006	A1-4034	KL-9401-08	FT-45051V3	13K45X52-A1	A 06040				30-45-52	2.0 -1.3	R-8
RCA 007	A1-4037	KL-9401-06	FT-45059X1	15J45G52-A1	A 06336				37-45-52	1.8 -1.5	R-6
RCA 008	A1-4025			15M45U60-A1	A 05336				15-45-60	1.8 -1.5	
RCA 009	A1-4077			15M45X52-A1	A 07036				30-45-52	1.8 -1.5	R-34
RCA 010	A1-4177			15K45X60-A1	A 07840				30-45-60	2.0 -1.5	
RCA 011	A1-4986			15Q45X60-A1					30-45-60	3.0 -1.5	
RCA 012	A1-4135			16F45X52-A1	A 07524				30-45-52	1.2 -1.6	
RCA 013	A1-4136		FT-45063V3	16F45X60-A1	A 07624				30-45-60	1.2 -1.6	
RCA 014	A1-4391	KL-9401-34		16G45X60-A1	A 09728				30-45-60	1.4 -1.6	
RCA 015	A1-4481			16H45U60-A1	A 10032				15-45-60	1.6 -1.6	
RCA 016	A1-4482			16H45X52-A1	A 10132				30-45-52	1.6 -1.6	
RCA 017				16H45X60-A1	A 09432				30-45-60	1.6 -1.6	
RCA 018	A1-4361		FT-45063W1	16M45X52-A1	A 09636				30-45-52	1.8 -1.6	
RCA 019	A1-4117			16K45U60-A1					15-45-60	2.0 -1.6	
RCA 020	A1-4266			16K45X52-A1	A 08740				30-45-52	2.0 -1.6	
RCA 021	A1-4040	KL-9401-36	FT-45063V2	16K45X60-A1	A 06640				30-45-60	2.0 -1.6	R-29
RCA 022	A1-4258			16Q45X60-A1	A 08660				30-45-60	3.0 -1.6	
RCA 023	A1-4483			18Q45X60-A1	A 10260				30-45-60	3.0 -1.8	
RCA 024	A1-4299	KL-9401-37		19F45X52-A1	A 08924				30-45-52	1.2 -1.9	
RCA 025	A1-4306			19F45X60-A1	A 09124				30-45-60	1.2 -1.9	
RCA 026	A1-4339			19H45X60-A1	A 09332				30-45-60	1.6 -1.9	
RCA 027	A1-4146	KL-9401-30		19M45X52-A1	A 07736				30-45-52	1.8 -1.9	



Rottler #	Newen #	K-line	Goodson	Serdi old #	Sunnen #	Other Ref #	Serdi-italy	R-1 refof	Top-Seat-Throat Angle	Top-seat width	Regis #
RCA 028	A1-4484			19K45X52-A1	A 10340				30-45-52	2.0-1.9	
RCA 029	A1-4042	KL-9401-15	FT-45075V1	19K45X60-A1	A 06840				30-45-60	2.0-1.9	R-15
RCA 030	A1-4236			20H45X70-A1	A 08332				30-45-70	1.6-2.0	
RCA 031	A1-4485			20H45X75-A1	A 10432				30-45-75	1.6-2.0	
RCA 032				22G45X60-A1	A 10512				30-45-60	1.4-2.2	
RCA 033	A1-4348			23K45X60-A1	A 09236				30-45-60	2.0-2.3	
RCA 034	A1-4487			25K45X60-A1	A 10640				30-45-60	2.0-2.5	
RCA 035	A1-1102	KL-9401-32	FT-45039U1	10G45V60-A1	A 04328	410A1 (1365)			25-45-60	1.4-1.0	
RCA 036	A1-1103	KL-9401-33	FT-45039U2	10I45V60-A1	A 04436				25-45-60	1.8-1.0	
RCA 037	A1-4029	KL-9401-23	FT-45039W1	10H45F52-A1	A 05532				35-45-52	1.6-1.0	R-23
RCA 038	A1-4030	KL-9401-10	FT-45039W2	10H45F55-A1	A 05632				35-45-55	1.6-1.0	R-10
RCA 039	A1-4031	KL-9401-09	FT-45039W3	10H45F60-A1	A 05732				35-45-60	1.6-1.0	R-9
RCA 040	A1-4035	KL-9401-54	FT-45051V1	13K45X60-A1	A 06140				30-45-60	2.0-1.3	R-27
RCA 041	A1-4032	KL-9401-03	FT-45051V2	13E45X60-A1	A 05820				30-45-60	1.0-1.3	R-3
RCA 042	A1-4036	KL-9401-13	FT-45055V1	14E45X60-A1	A 06220				30-45-60	1.0-1.4	R-13
RCA 043	A1-4038	KL-9401-01	FT-45059V1	15I45X60-A1	A 06436				30-45-60	1.8-1.5	R-1
RCA 044	A1-4216		FT-45059V2	15G45X60-A1	A 08128				30-45-60	1.4-1.5	
RCA 045	A1-1162		FT-45063U1	16G45V60-A1	A 04728				25-45-60	1.4-1.6	
RCA 046	A1-1163	KL-9401-35	FT-45063U2	16I45V60-A1	A 04836				25-45-60	1.8-1.6	
RCA 047	A1-4039	KL-9401-12	FT-45063V1	16E45X60-A1	A 06520				30-45-60	1.0-1.6	R-12
RCA 048			FT-45067V1	17K45X60-A1					30-45-60	2.0-1.7	
RCA 049	A1-4041	KL-9401-14	FT-45071V1	18H45X60-A1	A 06732				30-45-60	1.6-1.8	R-14
RCA 050	A1-4145		FT-45075V2	19D45X52-A1					30-45-52	0.8-1.9	
RCA 051	A1-1202	KL-9401-38	FT-45079U1	20G45V60-A1	A 04928	420A1 (1588)	4203 A1		25-45-60	1.4-2.0	
RCA 052	A1-1203	KL-9401-52	FT-45079U2	20I45V60-A1					25-45-60	1.8-2.0	
RCA 053	A1-4043	KL-9401-07	FT-45079V1	20F45X60	A 06924				30-45-60	1.2-2.0	
RCA 054	A1-1252	KL-9401-39	FT-45098U1	25G45V60-A1	A 05028				25-45-60	1.4-2.5	
RCA 055	A1-1253	KL-9401-53	FT-45098U2	25I45V60-A1					25-45-60	1.8-2.5	



Rottler #	Newen #	K-line	Goodson	Serdi old #	Sunnen #	Other Ref #	Serdi-italy	R-1 ref of	Top-Seat-Throat Angle	Top-seat width	Regis #
RCA 056	A1-4090	KL-9401-26		10J45X60	A 07136				30-45-60	1.8-1.0	
RCA 057	A1-4087	KL-9401-27		10K45G52					37-45-52	2.0-1.0	
RCA 058	2165-R								25-45-52	1.9-1.6	
RCA 059	2166-R								25-45-52	2.3-1.7	
RCA 060	A1-4109			15E45U60 A1			4151 A1		15-45-60	1.0-1.5	
RCA 061	A1-4003			15G45V60 A1	415A1 (532)		4154 A1		25-45-60	1.4-1.5	
<u>RCA 062</u> <u>Special</u>		KL-9401-59			A23128- small				75-30-45-55	4.5-1.34-2.03	
<u>RCA 063</u> <u>Special</u>		KL-9401-59 R			A23228- small				75-30-45-55	4.5-1.34-2.03	
RCA 064	A1-4183								32-45-60	1.0-0.8	
RCA 065	A1-1101			10E45V60					25-45-60	1.0-1.0	
<u>RCA 066</u> <u>Special</u>	A1-4006			42001-A1					30-45-60	1.5-2.0	
RCA 067	A1-1302								30-45-60	1.4-3.0	
RCA 068	A1-4445			10E45 U60 A1			4101-A1		15-45-60	1.0-1.0	
RCA 069	A1-4012								15-45-60	1.0-2.0	
RCA 070	A1-4082			41050-A1					30-45-70	0.8-1.3	
RCA 071	A1-4261			15G45U60 A1	A 21228		4153 A1		15-45-60	1.4-1.5	
RCA 072	A1-4989				A 21328				15-45-60	1.4-2.0	
RCA 073	A1-4016								15-45-60	1.8-1.2	
RCA 074	A1-4015			15K45U60-A1	A 05240				15-45-60	2.0-1.5	
<u>RCA 075</u> <u>Special</u>	A1-4007								30-45-60	1.0-1.8	
<u>RCA 076</u> <u>Special</u>	A1-1141								25-45-60	1.0-1.4	
<u>RCA 077</u> <u>Special</u>	A1-1122								25-45-60	1.4-1.2	
RCA 078									15-45-75	1.4-1.5	
<u>RCA 079</u> <u>Special</u>	A1-4241			15G45V52-A1	A 08428				25-45-52	1.4-1.5	
<u>RCA 080</u> <u>Special</u>	A1-4588								25-45-52	1.6-1.0	
RCA 081	A1-4093								30-45-60	2.0-1.4	



Rottler #	Newen #	K-line	Goodson	Serdi id #	Sunnen #	Other Ref #	Serdi-italy	R-1 ref of	Top-Seat-Throat Angle	Top-seat width	Regis #
RCA 082	A1-4486								30-45-60	0.6-2.2	
RCA 083	A1-4343								30-45-60	2.0-2.2	
RCA 171											
RCA 300	A1-3023	KL-9401-02	FT-30051S1	13E30U45-A1	A 00820				15-30-45	1.0-1.3	R-2
RCA 301	A1-3065			13K30U45-A1	A 01540				15-30-45	2.0-1.3	
RCA 302	A1-3061			13K30U60-A1	A 01240				15-30-60	2.0-1.3	
RCA 303	A1-3068			15G30U45-A1	A 01728				15-30-45	1.4-1.5	
RCA 304	A1-3064			15I30U45-A1	A 01436				15-30-45	1.8-1.5	
RCA 305	A1-3200	KL-9401-41	FT-30059S3	15K30U60-A1	A 02740				15-30-60	2.0-1.5	
RCA 306	A1-3078			16F30U45-A1	A 01924				15-30-45	1.2-1.6	
RCA 307	A1-3194			16I30U45-A1	A 02236				15-30-45	1.8-1.6	
RCA 308	A1-3195			16I30U52-A1	A 02336				15-30-52	1.8-1.6	
RCA 309	A1-3026	KL-9401-42	FT-30063S1	16K30U45-A1	A 00940				15-30-45	2.0-1.6	R-28
RCA 310	A1-3067			16K30U60-A1	A 01640				15-30-60	2.0-1.6	
RCA 311	A1-4997			16I30U60-A1					15-30-60	2.2-1.6	
RCA 312	A1-3146			18K30U45-A1	A 02140				15-30-45	2.0-1.8	
RCA 313	A1-3072	KL-9401-43	FT-30075S1	19E30U45-A1	A 01820				15-30-45	1.0-1.9	R-30
RCA 314	A1-3029	KL-9401-17	FT-30075S2	19K30U60-A1	A 01140				15-30-60	2.0-1.9	R-17
RCA 315	A1-3196			20F30U45-A1	A 02424				15-30-45	1.2-2.0	
RCA 316	A1-3084			20K30U45-A1	A 02040				15-30-45	2.0-2.0	
RCA 317	A1-3198			22K30U60-A1	A 02540				15-30-60	2.0-2.2	
RCA 318	A1-3199			38Q30D45-A1	A 02660				20-30-45	3.0-3.8	
RCA 321	A1-3062	KL-9401-19	FT-30039T1	10H30D52-A1	A 01332				20-30-52	1.6-1.0	R-19
RCA 322	A1-3024	KL-9401-21	FT-30059P1	15K30R60-A1					0-30-60	2.0-1.5	R-21
RCA 323	A1-2153	KL-9401-40	FT-30059S1	15I30U60-A1	A 00236				15-30-60	1.8-1.5	
RCA 324			FT-30059S2	15I30U60-A1					15-30-60	2.2-1.5	
RCA 325	A1-3025	KL-9401-20	FT-30059T1	15Q30D60-A1					20-30-60	3.0-1.5	R-20
RCA 326	A1-2202	KL-9401-22	FT-30079S1	20G30U60	A 00328		3201 A1		15-30-60	1.4-2.0	R-22



Rottler #	Newen #	K-line	Goodson	Serdi old #	Sunnen #	Other Ref #	Serdi-italy	R-1 ref of	Top-Seat-Throat Angle	Top-seat width	Regis #
RCA 327	A1-2203		FT-30079S2	20I30U60-A1					15-30-60	1.8-2.0	
RCA 328	A1-2253		FT-30098S1	25I30U60-A1					15-30-60	1.8-2.5	
RCA 329	A1-3032	KL-9401-18	FT-30098S2	25K30U60-A1					15-30-60	2.0-2.5	R-18
RCA 330	A1-2252	KL-9401-44		25G30U60	A 00428				15-30-60	1.4-2.5	
RCA 331	A1-3027	KL-9401-16	FT-3007IS1	18G30U60-A1	A 01028				15-30-60	1.4-1.8	R-16
RCA 332	A1-3031	KL-9401-25	FT-30110P1	28K30R60-A1					0-30-60	2.0-2.8	R-25
RCA 333									5/30/60	2-2.2	
RCA 334	A1-2152			15G30U60-A1	315A (551)		3151 A1		15-30-60	1.4-1.5	
RCA 335	A1-3245								15-30-60	1.0-1.2	
RCA 336	A1-2102								15-30-60	1.4-1.0	
RCA 337									15-30-60	2.0-2.0	
RCA 338									15-30-60	2.0-4.57	
RCA 339									15-30-60	1.8-1.5	
RCA 340	A1-2302			30G30U60-A1			3301 A1		15-30-60	1.4-3.0	
RCA 348											
RCA 365											
RCA 400	A1-5414			16G37.5X60-A1	A 03728				30-37.5-60	1.4 - 1.6	
RCA 401	A1-5415			16K37.5X60-A1	A 03840				30-37.5-60	2.0-1.6	
RCA 402	A1-5416			19G37.5X60-A1	A 03928				30-37.5-60	1.4-1.9	
RCA 403	A1-5417			20K37.5X60-A1	A 04040				30-37.5-60	2.0-2.0	
RCA 404				21G37.5C52-A1	A 04112				18-37.5-52	1.4-2.1	
RCA 405			FT-37063S60	16G37.5U60					15-37.5-60	1.4 - 1.6	
RCA 406	A1-5006	KL-9401-29	FT-37071S52	18F37.5D52	A 03524				20-37.5-52	1.2-1.8	R-33
RCA 407			FT-37079S60	20G37.5U60					15-37.5-60	1.4 - 1.6	
RCA 500	A1-0015	KL-9401-45	FT-15	15-A1	A 14300				15 degrees	7.7mm	
RCA 501	A1-0020		FT-20	20-A1	A 14400				20 degrees	8.8mm	
RCA 502	A1-0030	KL-9401-47	FT-30	30-A1	A 14600				30 degrees'	9.0 mm	R-31



Rottler #	Newen #	K-line	Goodson	Serdi old #	Sunnen #	Other Ref #	Serdi-italy	R-1 ref of	Top-Seat-Throat Angle	Top-seat width	Regis #
RCA 503	A1-0045	KL-9401-48	FT-45	45-A1	A 14900				45 degrees'	8.9 mm	R-32
RCA 504	A1-4888			45.15-A1					45 deg 15'	8.0 mm	
RCA 505	A1-0060	KL-9401-49	FT-60	60-A1	A 15000				60 degrees'	8.1 mm	
RCA 507	A1-0075	KL-9401-50	FT-75	75-A1	A 15200				75 degrees	8.3mm	
RCA 511	A1-90-12			L-11					94 deg-R 0.8	12 mm	
RCA 512	A1-90-16	KL-9401-24	FT-90	L-12					94 deg-R 0.8	15.3 mm	R-24
RCA 513				L-12 -offset					94-R0.5	2.5-6.5	
RCA 521	A1-0025	KL-9401-46	FT-25	25-A1	A 14500				25 degrees'	8.5 mm	
RCA 522	A1-0070	KL-9401-04	FT-70		A 15100				70 degrees'	7.7 mm	
RCA 524	A1-0082	KL-9401-51	FT-82	82-A1	A 15400				82 degrees'	7.07 mm	
RCA 525	A1-91-16								94-CHAMER 60 DEGREE		
RCA 526									45 DEGREES	11.97mm	
RCA 527	A1-0037		FT-37	37-A1	A 14800				37 degrees'	9.3 mm	
RCA 611	A1-5074			HP1126-A1					R1.5-15-30-45-60-75	2.2-0.8	
RCA 612	A1-5447			HP1179-A1					R1.2-25-45-65-75	1.2-0.8	
RCA 613	A1-5073			HP1118-A1					R2-30-45-60-R7	1.9-0.8	
RCA 614	A1-5121		FT-5121A-HP	R4-15-A1	A 13300				R4 -15	5.52 mm	
RCA 615	A1-5168			R4-30-A1	A 13400				R4 -30	5.70 mm	
RCA 616	A1-5428			R5-15-A1	A 13500				R5 -15	5.00 mm	
RCA 617	A1-5079			R5-30-A1	A 13200				R5 -30	6.00 mm	
RCA 618	A1-5429			R7-15-A1	A 13600				R7 -15	4.4 mm	
RCA 619	A1-5430			R7-30-A1	A 13700				R7 -30	4.4 mm	
RCA 623	A1-5118		FT-5118A-HP	HP1096-A1					R0.8-30-45-60-R13-R1.5	1.3-1.0	
RCA 624	A1-4496			40805 -A1	A 10726				R1-32-45-60	1.3-0.8	
RCA 625	A2-4496			40805-A2	A 16196				30-R1.5-32-45-60	0.7-0.8	
RCA 626	A1-5043		FT-5043A- HD	41001-A1	A 11032				R1.5-30-45-60	1.6-1.0	
RCA 627	A1-5448			41003-A1	A 12240				R1.5-15-45-75	1.0-1.0	



Rottler #	Newen #	K-line	Goodson	Serdi old #	Sunnen #	Other Ref #	Serdi-italy	R-1 ref of	Top-Seat-Throat Angle	Top-seat width	Regis #
RCA 628	AZ-5448			41003-A2	A 16796				30-R1.5-15-45-75	1.0-1.0	
RCA 629	A1-4498			41026-A1	A 10926				R1.5-38-45-60	1.3-1.1	
RCA 630	AZ-4498			41026-A2	A 16396				30-94-R1.5-38-45-60	1.3-1.1	
RCA 631	A1-5449			41046-A1	A 12232				R1.5-30-45-60	1.6-1.3	
RCA 632	AZ-5449			13H45X60-A1	A 16896				30-94-R1.5-30-45-60	1.6-1.3	
RCA 633				41065-A1					R1.5-32-45-60	1.0-1.0	
RCA 634	A1-5436			41091-A1	A 11732				R1.6-30-45-60	1.6-1.5	
RCA 635	AZ-5436			41091-A2	A 16496				30-94-R1.5-30-45-60	1.6-1.5	
RCA 636				41156-A1					R1.5-32-45-60	1.6-1.0-1.0	
RCA 637	AZ-4497			41156-A2	A 16296				R1.5-32-45-60	1.6-1.0-1.0	
RCA 638	A1-5439			41181-A1	A 11832				R1.5-30-45-75	1.6-1.0	
RCA 639	AZ-5439			41181-A2	A 16596				30-R1.5-30-45-75	1.0-1.0	
RCA 640	A1-4497		FT-4247A- HD	41182-A1	A 10832				R1.5-32-45-60	1.0-1.2	
RCA 641				41182-A2	A 08530				R1.5-32-45-60	1.0-1.2	
RCA 642	A1-5442			41200-A1	A 11938				R1.5-20-45-60	1.9-1.0	
RCA 643	AZ-5442			41200-A2	A 16696				30-R1.5-20-45-60	1.0-1.0	
RCA 645	A1-5444			HP1121-A1					R2-37-45-52-R7	1.5-0.8	
RCA 655	A1-21050	KL-9401-05	FT-R5	R-5-A1					R 5.00'	16.00mm	R-5
RCA 656	A1-5119		FT-5119A-HP	451515R10S					30-45-R10	1.5-1.5	
RCA 723	Z6A1-2327								5/20/45	2.0-2.0	
RCA 730	Z6A1-2402								5/20/45	2.0-3.2	
RCA 731	Z6A1-2091								11/20/45	1.8-3.8	
RCB 506	B3-070			70-B3					70 degrees'	16.8 mm	R-4
RCB 508	B3-085		FT-085B-HP	75-B3					75 degrees'	16.4 mm	
RCB 509	B3-080			80-B3					80 degrees'	12.1 mm	
RCB 510	B3-082			82-B3					82 degrees'	11.5 mm	
RCB-600	B1-068		FT-068B-HP	H1-1N1-B1					R2.5-38-45-60	2.5-2.4-1.00	



Rottler #	Newen #	K-line	Goodson	Serdold #	Sonnen #	Other Ref #	Serd-Italy	R-1 refof	Top-Seat-Throat Angle	Top-seat width	Regis #
RCB-601	B1-069		FT-069B-HP	H1N1-B1					R1-35-45-60-75	1.5-1.3-1.0-2.5	
RCB 602	B1-081		FT-081B-HP	H1X1-B1					R1.0-35-45-56	2.0-1.3	
RCB 603	B1-084		FT-084B-HP	H1X2-B1					R12 -45 deg		
RCB 604	B1-072			HP-2028-B1					R2-35-45-60-75-82	2.9-1.3-1.7-2.2	
RCB 605	B1-073			HP2029-B1					35-45-55-65-75	2.5-1.0-2.5-2.5	
RCB 606	B1-074			41055-B1					40-45-55-65-75	2.5-1.3-2.5-2.5	
RCB 607	B3-003		FT-003B-HP	S 9024-B1					R1.5-35-45-R12-75-R3.5	1.9-1.5-1.5-3.0	
RCB 608	B3-005		FT-005B-HP	S 9026-B1					R1.5-35-45-R12-75-R3.5-45	1.9-1.5-1.0-3.0	
RCB 609	B1-083			HP1625-B1					R1.5-35-45-R12-75	1.9-1.5-2.5-3.0	
RCB 610	B1-076			HP1750-B1					R1.5-35-45-R12.2-85	1.8-1.5-1.5-3.0	
RCB 620	B1-077		FT-077B-HP	R7BC-B1					R7 -15		
RCB 621	B3-002		FT-002B-HP	75-R7-B3					75 - R7	12.0 mm	
RCB 622	B3-033		FT-033B-HP	80 R 7-B3					80 - R7	9.00 mm	
RCB 644	B1-078			HP1321-B1					R3-30-R13-45-75-R3	2.5-1.2-1.2-3.0	
RCB 646	B1-079			09G45F6SR2-B1					R2 -35-45-65	2.0-1.4 - 0.8	
RCB 651	B4-213		FT-213B-HP						30-94-30-45-60	3.1-1.5-3.0	
RCB 652	B4-215		FT-215B-HP						30-94-32-45-60	1.0-0.8	
RCB 653	B4-4028	KL-9401-31	FT-4028B-HP	10F45X60-B4					30-45-60	1.2-1.0	
RCB 654	B4-90-20		FT-9020-HP	75-B4					45-91	19.6-6.3 mm	
RCB 695											
RCB 696											
RCB 697											
RCB 698											
RCB 699											
RCB 700											
RCC 701 <i>Special</i>								RCA-500	15 degrees'	10.2	
RCC 702								RCA-501	20 degrees'	9.8	



Rottler #	Newen#	K-line	Goodson	Serdi old #	Sunnen #	Other Ref #	Serdi-italy	R-1 refof	Top-Seat-Throat Angle	Top-seat width	Regis #
RCC 703								RCA-502	30 degrees'	10.5	
RCC 704								RCA-503	45 degrees'	10.2	
RCC 705								RCA-512	94 deg-R 0.8	18mm	
RCC 706											
RCC 721	Z6A1-5183								0-20-60	1.8-2.0	
RCC 722	Z6A1-2133								0-20-75	2.0-2.0	
RCC 723	Z6A1-2327								5/20/45	2.0-2.0	
RCC 724	Z6A1-2266								10/20/75	2.0-2.3	
RCC 725	Z6A1-5022								0-20-60	1.8-2.5	
RCC 726	Z6A1-2200								5/20/75	2.0-2.5	
RCC 727	Z6A1-4599								15-20.25-60	3.0-2.5	
RCC 728	Z6A1-5116								15-20-60	2.8-2.66	
RCC 729									5/20/45	3.0-3.0	
RCC 730	Z6A1-2402								5/20/45	2.0-3.2	
RCC 731	Z6A1-2091								11/20/45	1.8-3.8	
RCC 741								RCA-338	15-30-60	2.0-4.6	
RCC 742											
RCC 743											
RCC 761											
RCC 762											
RCC 763											
RCC 764											
RCC 765											
RCC 767											
RCC 768											
RCC 769											
RCC 770											
RCC 771											

Custom Insert Profile Order Form

Custom Form for Special Profile Inserts A or B Style Inserts

Rottler A Style Insert (RCA profile)

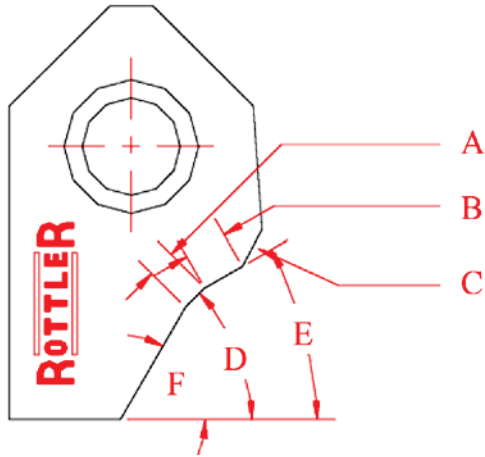

Seat Angle Width (A) =	_____
Top Angle Width (B) =	_____
Seat Angle (D) =	_____
Top angle (E) =	_____
Throat Angle(F) =	_____
Top Radius (C) =	_____

Rottler B Style Insert (RCB profile)

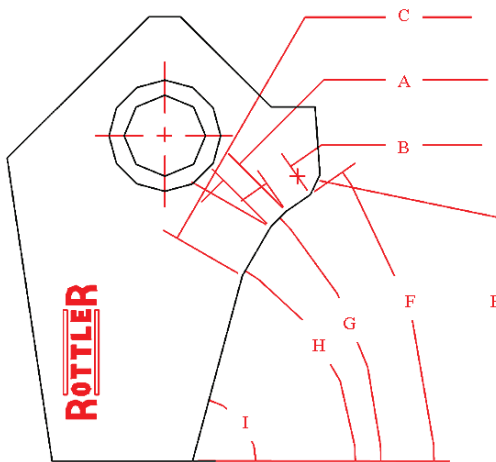

Seat Angle (G) =	_____
Seat Angle Width (A) =	_____
Top Angle (F) =	_____
Top Angle Width (B) =	_____
Top Radius (E) =	_____
Throat Angle Width(C) =	_____
Throat Angle(H) =	_____
Throat Angle (I) =	_____
Throat Radius if preferred(I) =	_____

Customer Information

Company and Acct. #:	_____
Contact Person:	_____
Phone:	_____
Date:	_____

Prepared by Signature _____